

Service
Service
Service



Service Manual

TABLE OF CONTENTS

	Page
Location of PC Boards & Versions Variation	1-2
Specifications	1-3
Measurement Setup	1-4
Service Aids, Safety Instruction, etc	1-5 to 1-7
Disassembly Instructions & Service positions	2
Service Test Program	3
Set Block Diagram.....	4
Set Wiring Diagram	5
Main Board	6
ECO 6 Tuner Board : Systems Non Cenelec	7A
Subwoofer AMP Board	8
Display (MCU) Board.....	9
Key Boards	10
Mechanical Exploded View & Parts List	11



© Copyright 2006 Philips Consumer Electronics B.V. Eindhoven, The Netherlands
All rights reserved. No part of this publication may be reproduced, stored in a retrieval system or transmitted, in any form or by any means, electronic, mechanical, photocopying, or otherwise without the prior permission of Philips.

Published by SL 0649 Service Audio

Printed in The Netherlands

Subject to modification

GB 3141 785 31500



Version 1.0



PHILIPS

SPECIFICATIONS

AMPLIFIER

Output power 2 x 20 W+60W RMS
 Signal-to-noise ratio ≥ 60 dBA
 LR frequency response 130 " 18 kHz, ± 3 dB
 SUB Frequency response 50 " 120Hz, ± 3 dB
 Input sensitivity AUX 600mV
 Impedance loudspeakers 6 Ω
 Impedance headphones 32 Ω " 1000 Ω
 <0.5W
 (1) (6 Ω , 120-12.5 kHz, 10% THD)

CD PLAYER

Frequency range 40 - 18000 Hz
 Signal-to-noise ratio 60 dBA
 Total harmonic distortion $\leq 3\%$
 LR Frequency response 130 - 18 kHz, ± 3 dB
 SUB Frequency response 50 - 120Hz, ± 3 dB

TUNER

FM wave range 87.5 " 108 MHz
 MW wave range (9 kHz) 531 " 1602 kHz
 MW wave range (10 kHz) 530 " 1700 kHz
 Tuning grid 9/10 kHz
 Antenna
 " FM 300 Ω Wire
 " MW Loop antenna

SPEAKERS

Bass reflex system
 Dimensions (w x h x d) 171 x 297 x 89 (mm)

SUBWOOFER

Subwoofer (not magnetically shielded design).....
 15cm
 Impedance 6 Ω
 Dimensions (w x h x d)
 220 mm x 350 mm x 357 mm
 Weight 7.5 kg

GENERAL INFORMATION

AC Power 110 " 127 / 220 " 240 V;
 50/60 Hz Switchable
 Dimensions (w x h x d) . 450 x 335 x 115 (mm)
 Weight(with/without speakers) 6.5 / 4.2 kg
 Power consumption
 Active 60 W
 Standby <15 W

Specifications and external appearance are subject to change without notice.

MEASUREMENT SETUP

CD

Use Audio Signal Disc SBC429 4822 397 30184 (replaces test disc 3)
L.P.F. = 13th order filter 4822 395 30204

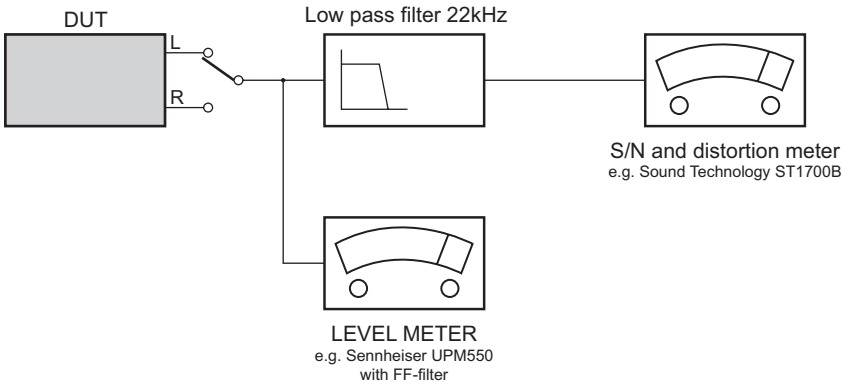

SERVICE AIDS

Service Tools:

Universal Torx driver holder	4822 395 91019
Torx bit T10 150mm	4822 395 50456
Torx driver set T6-T20	4822 395 50145
Torx driver T10 extended	4822 395 50423

Compact Disc:

SBC426/426A Test disc 5 + 5A	4822 397 30096
SBC442 Audio Burn-in test disc 1kHz	4822 397 30155
SBC429 Audio Signals disc	4822 397 30184
Dolby Pro-logic Test Disc	4822 395 10216

ESD Equipment:

Anti-static table mat - large 1200x650x1.25mm ...	4822 466 10953
anti-static table mat - small 600x650x1.25mm	4822 466 10958
Anti-static wristband	4822 395 10223
Connectorbox (1M Ω)	4822 395 11307
Extension cable (to connect wristband to conn.box)	4822 320 11305
Connecting cable (to connect table mat to conn.box)	4822 320 11306
Earth cable (to Connect product to mat or box) --	4822 320 11308
Complete kit ESD3 (combining all above products)	4822 320 10671
Wristband tester	4822 344 13999

HANDLING CHIP COMPONENTS

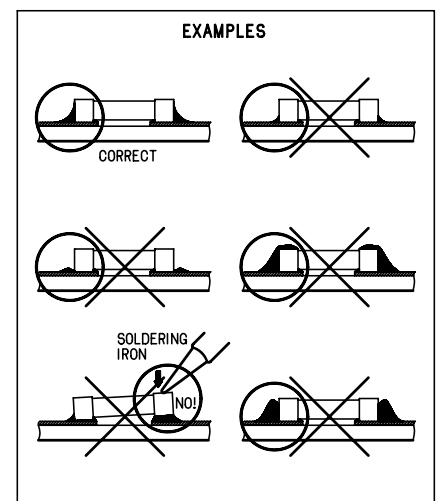
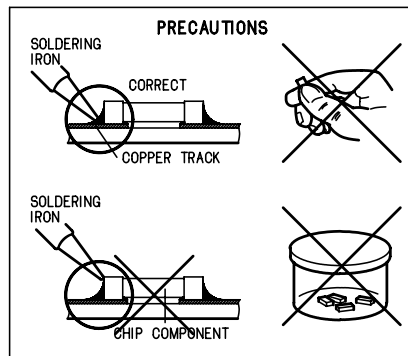
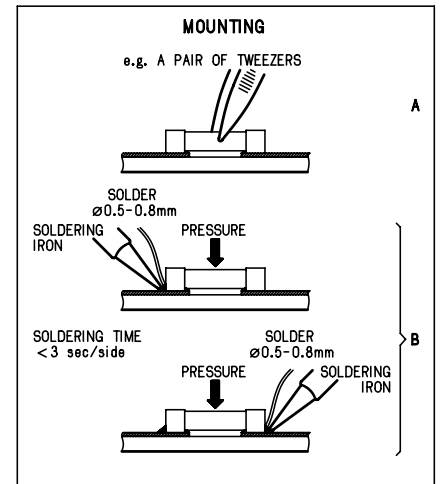
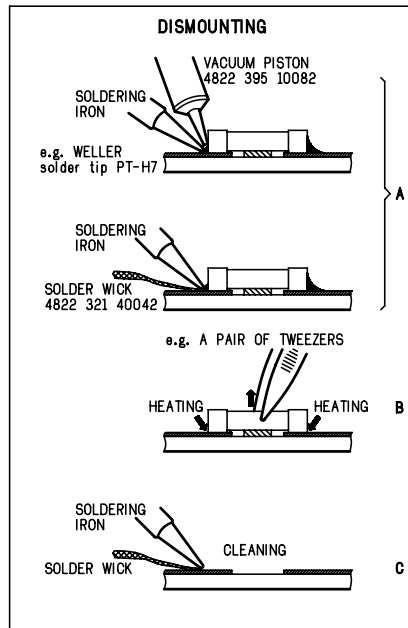
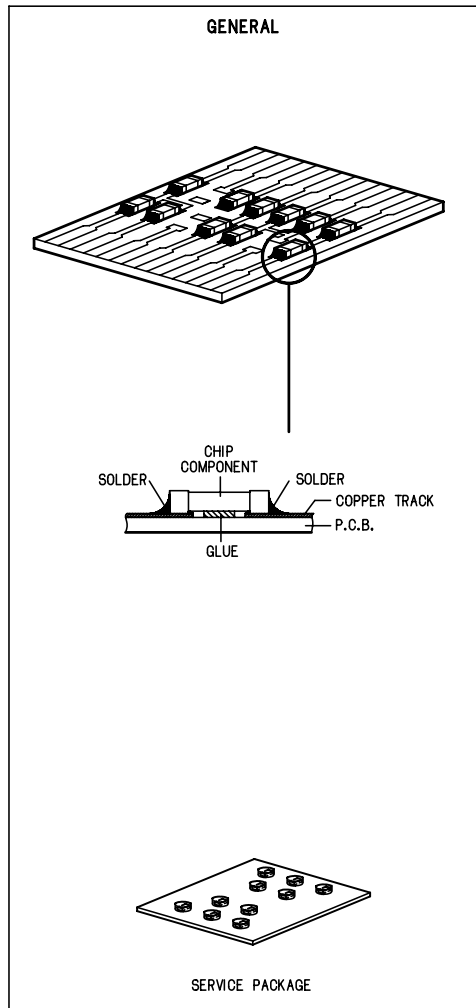

(GB) WARNING

All ICs and many other semi-conductors are susceptible to electrostatic discharges (ESD). Careless handling during repair can reduce life drastically.

When repairing, make sure that you are connected with the same potential as the mass of the set via a wrist wrap with resistance. Keep components and tools also at this potential.

(F) ATTENTION

Tous les IC et beaucoup d'autres semi-conducteurs sont sensibles aux décharges statiques (ESD).

Leur longévité pourrait être considérablement écourtée par le fait qu'aucune précaution n'est prise à leur manipulation.

Lors de réparations, s'assurer de bien être relié au même potentiel que la masse de l'appareil et enfilier le bracelet serti d'une résistance de sécurité.

Veiller à ce que les composants ainsi que les outils que l'on utilise soient également à ce potentiel.

(D) WARNUNG

Alle ICs und viele andere Halbleiter sind empfindlich gegenüber elektrostatischen Entladungen (ESD).

Unvorsichtige Behandlung im Reparaturfall kann die Lebensdauer drastisch reduzieren.

Veranlassen Sie, dass Sie im Reparaturfall über ein Pulsarmband mit Widerstand verbunden sind mit dem gleichen Potential wie die Masse des Gerätes.

Bauteile und Hilfsmittel auch auf dieses gleiche Potential halten.

(NL) WAARSCHUWING

Alle IC's en vele andere halfgeleiders zijn gevoelig voor electrostatische ontladingen (ESD). Onzorgvuldig behandelen tijdens reparatie kan de levensduur drastisch doen verminderen.

Zorg ervoor dat u tijdens reparatie via een polsband met weerstand verbonden bent met hetzelfde potentiaal als de massa van het apparaat.

Houd componenten en hulpmiddelen ook op hetzelfde potentiaal.

(I) AVVERTIMENTO

Tutti IC e parecchi semi-conduttori sono sensibili alle scariche statiche (ESD).

La loro longevità potrebbe essere fortemente ridotta in caso di non osservazione della più grande cauzione alla loro manipolazione.

Durante le riparazioni occorre quindi essere collegato allo stesso potenziale che quello della massa dell'apparecchio tramite un braccialetto a resistenza.

Assicurarsi che i componenti e anche gli utensili con quali si lavora siano anche a questo potenziale.

(GB) ESD PROTECTION EQUIPMENT:

Complete Kit ESD3 (small tablemat, wristband, connection box, extension cable and earth cable) 4822 310 10671
Wristband tester 4822 344 13999

(GB)

Safety regulations require that the set be restored to its original condition and that parts which are identical with those specified, be used

Safety components are marked by the symbol \triangle .

(NL)

Veiligheidsbepalingen vereisen, dat het apparaat bij reparatie in zijn oorspronkelijke toestand wordt teruggebracht en dat onderdelen, identiek aan de gespecificeerde, worden toegepast.

De Veiligheidsonderdelen zijn aangeduid met het symbool \triangle .

(F)

Les normes de sécurité exigent que l'appareil soit remis à l'état d'origine et que soient utilisés les pièces de rechange identiques à celles spécifiées.

Les composants de sécurité sont marqués \triangle .

(D)

Bei jeder Reparatur sind die geltenden Sicherheitsvorschriften zu beachten. Der Originalzustand des Geräts darf nicht verändert werden; für Reparaturen sind Original-Ersatzteile zu verwenden.

Sicherheitsbauteile sind durch das Symbol \triangle markiert.

(I)

Le norme di sicurezza esigono che l'apparecchio venga rimesso nelle condizioni originali e che siano utilizzati i pezzi di ricambio identici a quelli specificati.

Componenti di sicurezza sono marcati con \triangle .

(GB)

After servicing and before returning set to customer perform a leakage current measurement test from all exposed metal parts to earth ground to assure no shock hazard exist. The leakage current must not exceed 0.5mA.

ESD**(GB) Warning !**

Invisible laser radiation when open.
Avoid direct exposure to beam.

(S) Varning !

Osynlig laserstrålning när apparaten är öppnad och spärren är urkopplad. Betrakta ej strålen.

(SF) Varoitus !

Avatussa laitteessa ja suoalukituksen ohitettaessa olet alltiina näkymättömälle laserisäteilylle. Älä katso säteeseen!

(DK) Advarse !

Usynlig laserstråling ved åbning når sikkerhedsafbrydere er ude af funktion. Undgå udsættelse for stråling.

(F)

"Pour votre sécurité, ces documents doivent être utilisés par des spécialistes agréés, seuls habilités à réparer votre appareil en panne".

INFORMATION ABOUT LEAD-FREE SOLDERING

Philips CE is producing lead-free sets from 1.1.2005 onwards.

IDENTIFICATION:

Regardless of special logo (not always indicated) one must treat all sets from 1 Jan 2005 onwards, according next rules:



Example S/N:

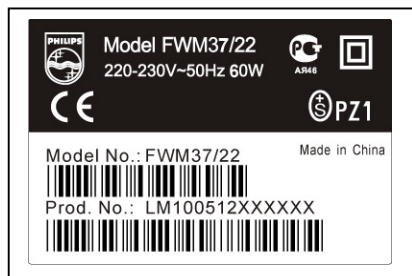

Bottom line of typeplate gives a 14-digit S/N. Digit 5&6 is the year, digit 7&8 is the week number, so in this case 2005 wk12

So from 0501 onwards = from 1 Jan 2005 onwards

Important note: In fact also products of year 2004 must be treated in this way as long as you avoid mixing solder-alloys (leaded/ lead-free). So best to always use SAC305 and the higher temperatures belong to this.

Due to lead-free technology some rules have to be respected by the workshop during a repair:

- Use only lead-free solder alloy Philips SAC305 with order code 0622 149 00106. If lead-free solder-paste is required, please contact the manufacturer of your solder-equipment. In general use of solder-paste within workshops should be avoided because paste is not easy to store and to handle.
- Use only adequate solder tools applicable for lead-free solder alloy. The solder tool must be able
 - To reach at least a solder-temperature of 400°C,
 - To stabilize the adjusted temperature at the solder-tip
 - To exchange solder-tips for different applications.
- Adjust your solder tool so that a temperature around 360°C – 380°C is reached and stabilized at the solder joint. Heating-time of the solder-joint should not exceed ~ 4 sec. Avoid temperatures above 400°C otherwise wear-out of tips will rise drastically and flux-fluid will be destroyed. To avoid wear-out of tips switch off un-used equipment, or reduce heat.
- Mix of lead-free solder alloy / parts with leaded solder alloy / parts is possible but PHILIPS recommends strongly to avoid mixed solder alloy types (leaded and lead-free).
If one cannot avoid or does not know whether product is lead-free, clean carefully the solder-joint from old solder alloy and re-solder with new solder alloy (SAC305).
- Use only original spare-parts listed in the Service-Manuals. Not listed standard-material (commodities) has to be purchased at external companies.
- **Special information for BGA-ICs:**
 - always use the 12nc-recognizable soldering temperature profile of the specific BGA (for de-soldering always use the lead-free temperature profile, in case of doubt)
 - lead free BGA-ICs will be delivered in so-called 'dry-packaging' (sealed pack including a silica gel pack) to protect the IC against moisture. After opening, dependent of MSL-level seen on indicator-label in the bag, the BGA-IC possibly still has to be baked dry. (MSL=Moisture Sensitivity Level). This will be communicated via AYS-website. Do not re-use BGAs at all.
- For sets produced before 1.1.2005 (except products of 2004), containing leaded solder-alloy and components, all needed spare-parts will be available till the end of the service-period. For repair of such sets nothing changes.
- On our website www.atyourservice.ce.Philips.com you find more information to:
 - * BGA-de-/soldering (+ baking instructions)
 - * Heating-profiles of BGAs and other ICs used in Philips-sets

You will find this and more technical information within the "magazine", chapter "workshop news".

For additional questions please contact your local repair-helpdesk.

SERVICE INSTRUCTION

Safety regulations require that after a repair, the set must be returned in its original condition. Pay in particular attention to the following points:

- Route the wire trees correctly and fix them with the mounted cable clamps.
- Check the insulation of the AC Power lead for external damage.
- Check the strain relief of the AC Power cord for proper function.
- Check the electrical DC resistance between the AC Power Plug and the secondary side (only for sets which have a AC Power isolated power supply):
 1. Unplug the AC Power cord and connect a wire between the two pins of the AC Power plug.
 2. Set the AC Power switch to the "on" position (keep the AC Power cord unplugged!).
 3. Measure the resistance value between the pins of the AC Power plug and the metal shielding of the tuner or the aerial connection on the set. The reading should be larger than 4.5 Mohm (For U.S. it should be between 4.2 Mohm and 12 Mohm).
 4. Switch "off" the set, and remove the wire between the two pins of the AC Power plug.
- Check the cabinet for defects, to avoid touching of any inner parts by the customer.

SERVICE TEST PROGRAM

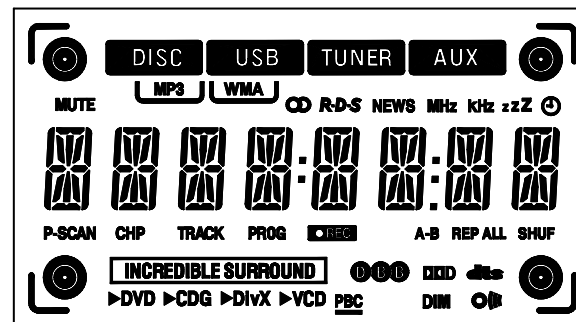
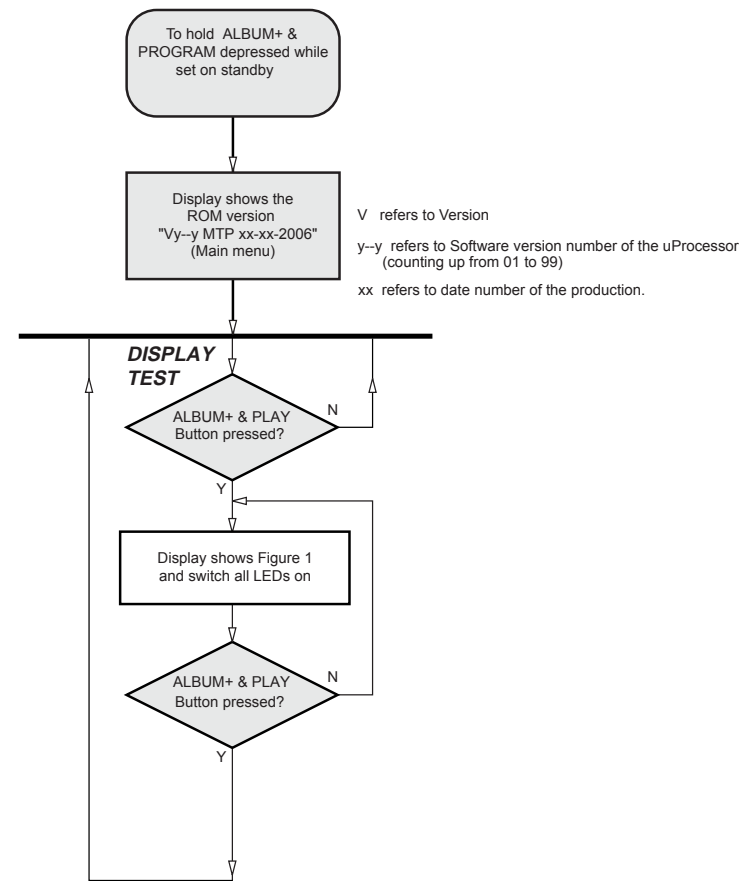
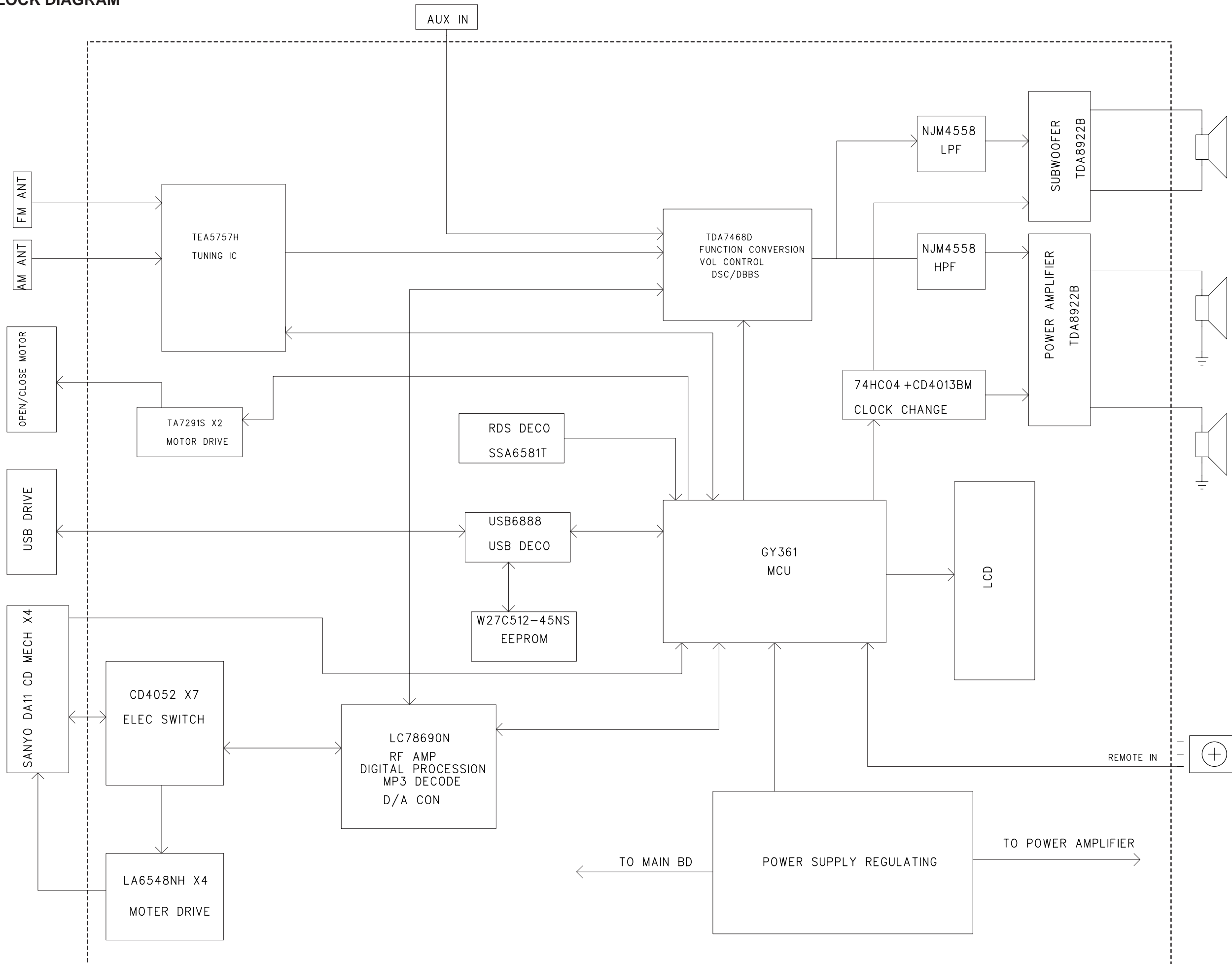
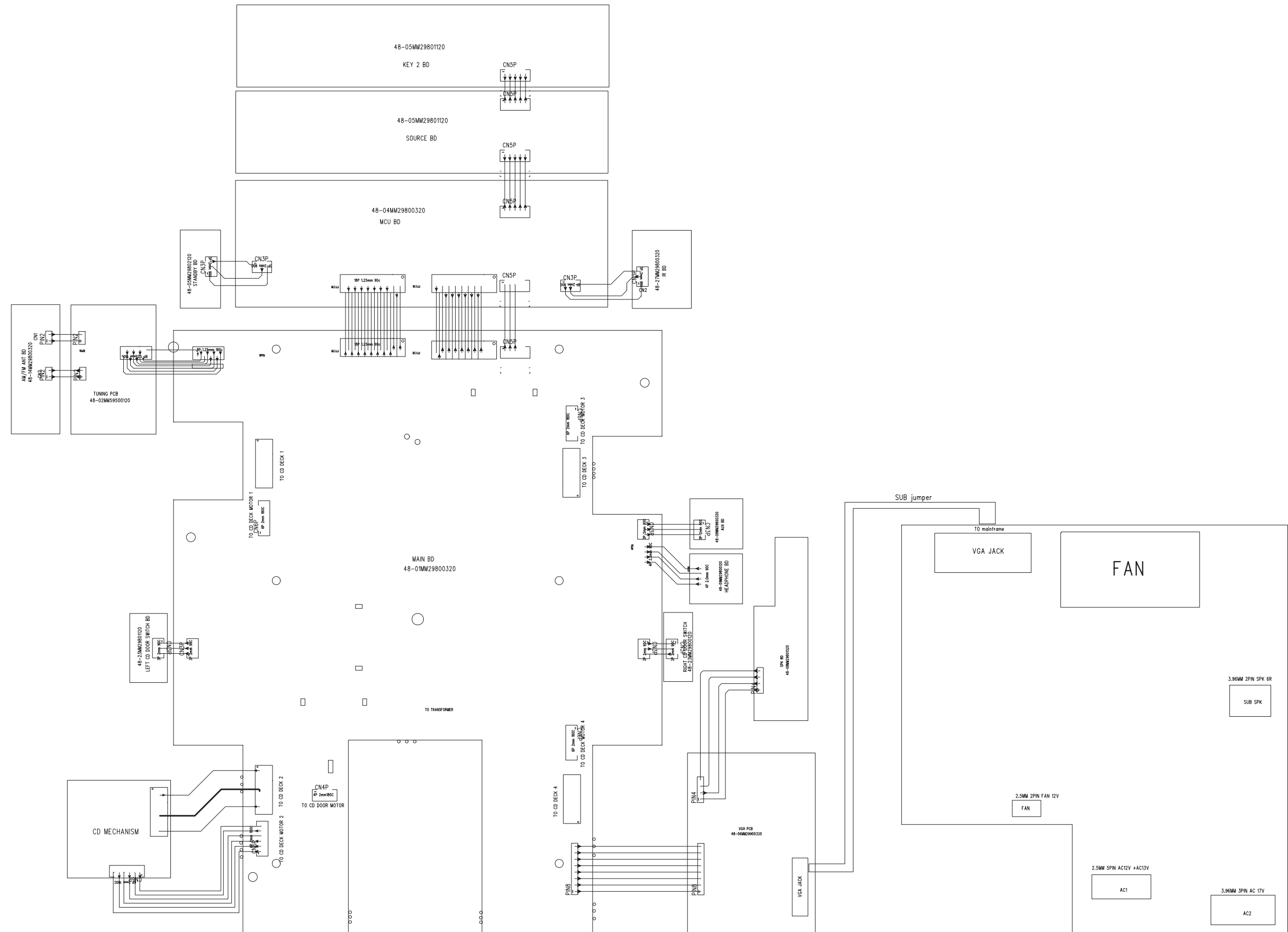

Figure 1

SET BLOCK DIAGRAM



SET WIRING DIAGRAM



MAIN BOARD

TABLE OF CONTENTS

Main PCB - Layout Top View	6-2
Main PCB - Layout Bottom View	6-3
Main PCB - Circuit Diagram (Audio Part)	6-4
Main PCB - Circuit Diagram (CD Part)	6-5
Class D Power PCB - Layout Top View	6-6

PCB LAYOUT - MAIN BOARD (TOP VIEW)

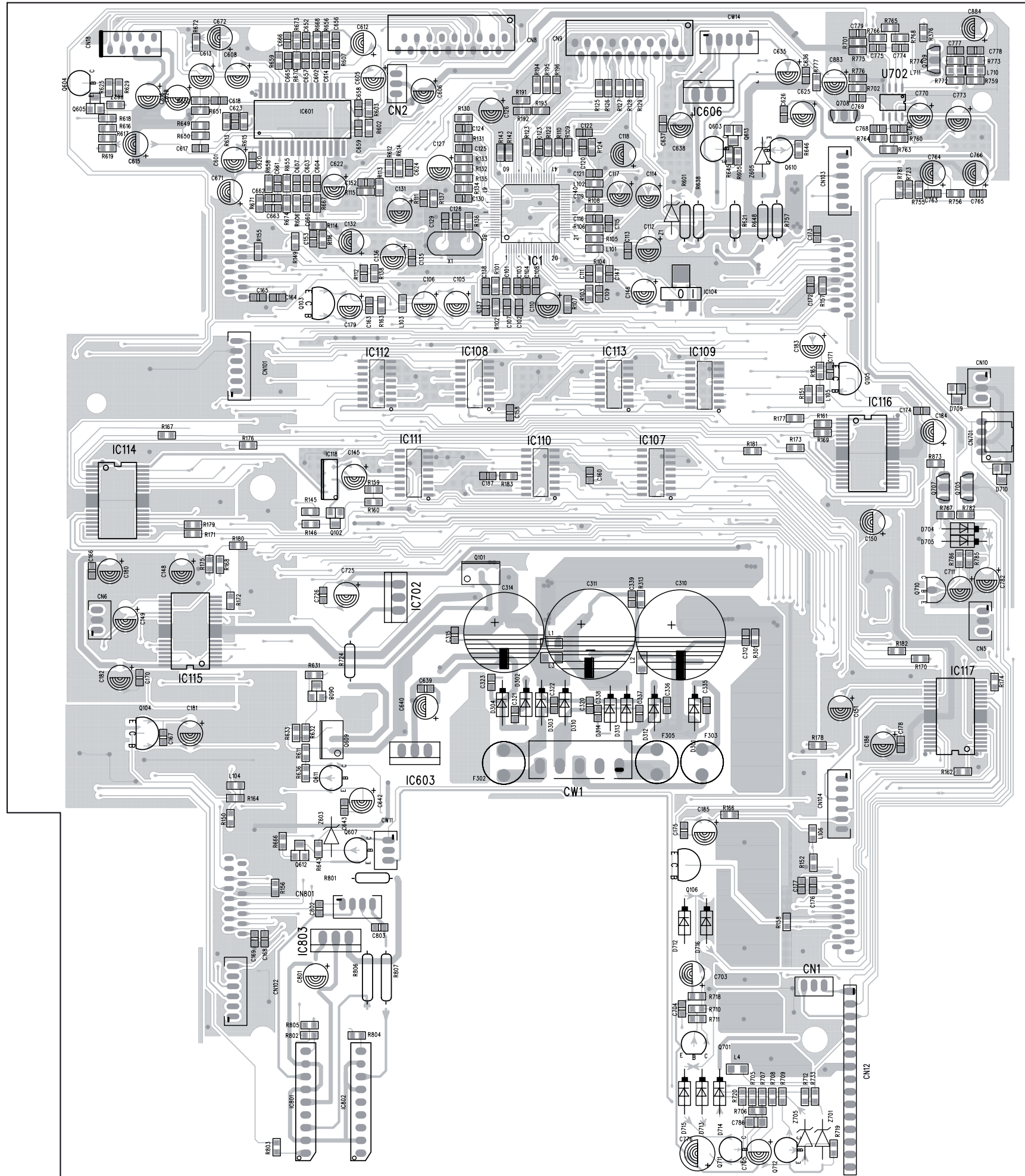

PCB LAYOUT - MAIN BOARD (BOTTOM VIEW)

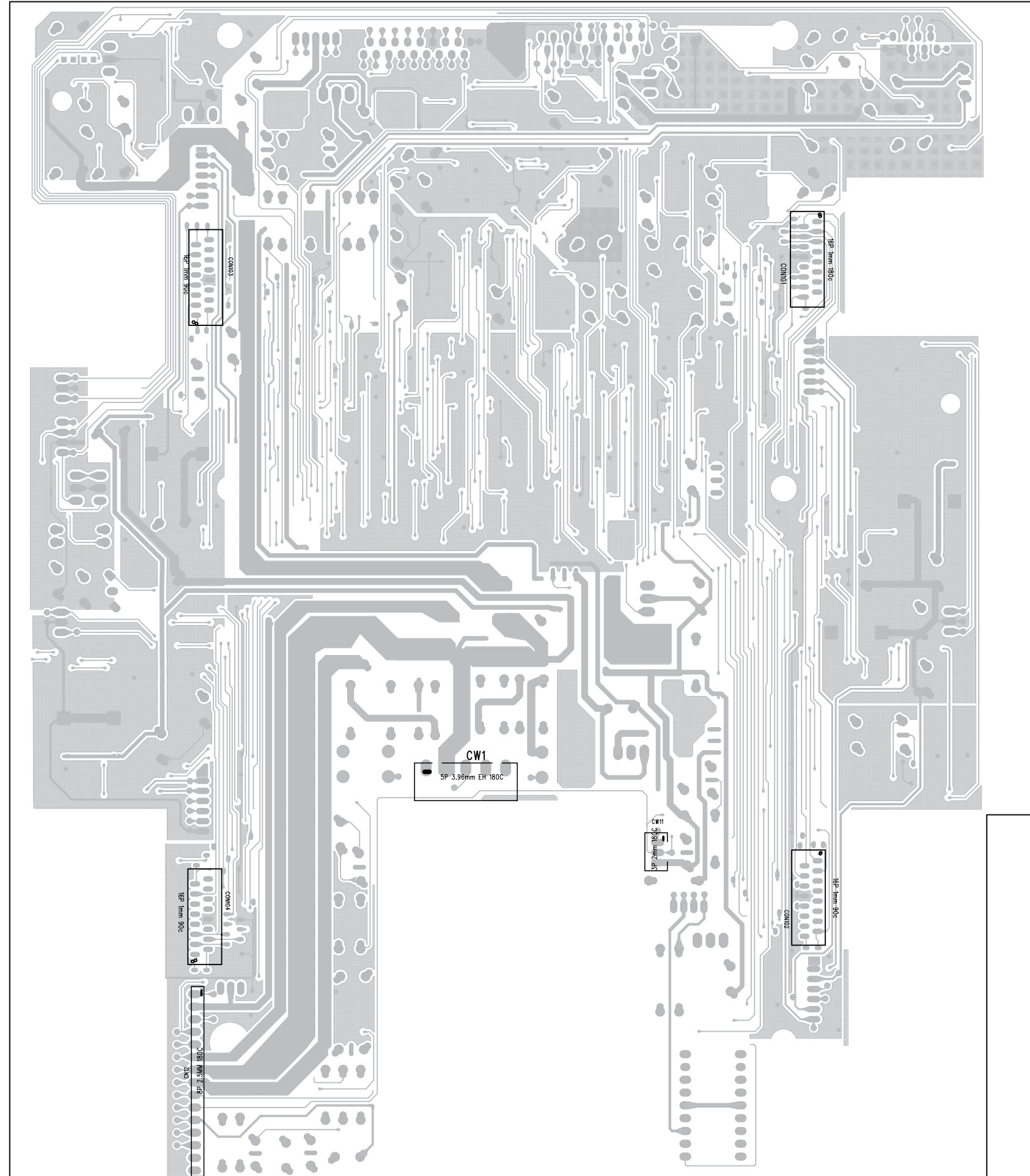

CIRCUIT DIAGRAM - MAIN BOARD AUDIO PART

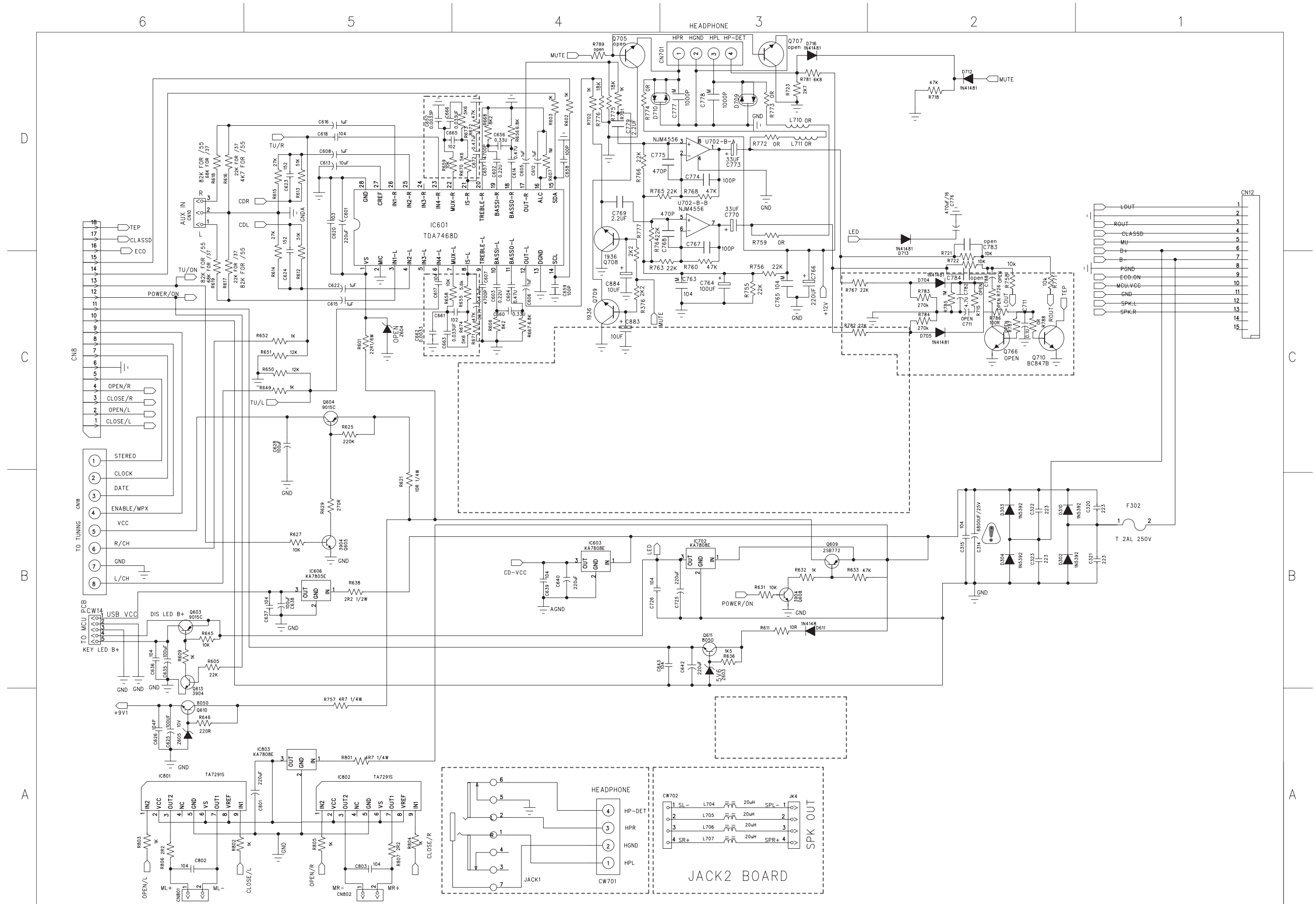

CIRCUIT DIAGRAM - MAIN BOARD CD PART

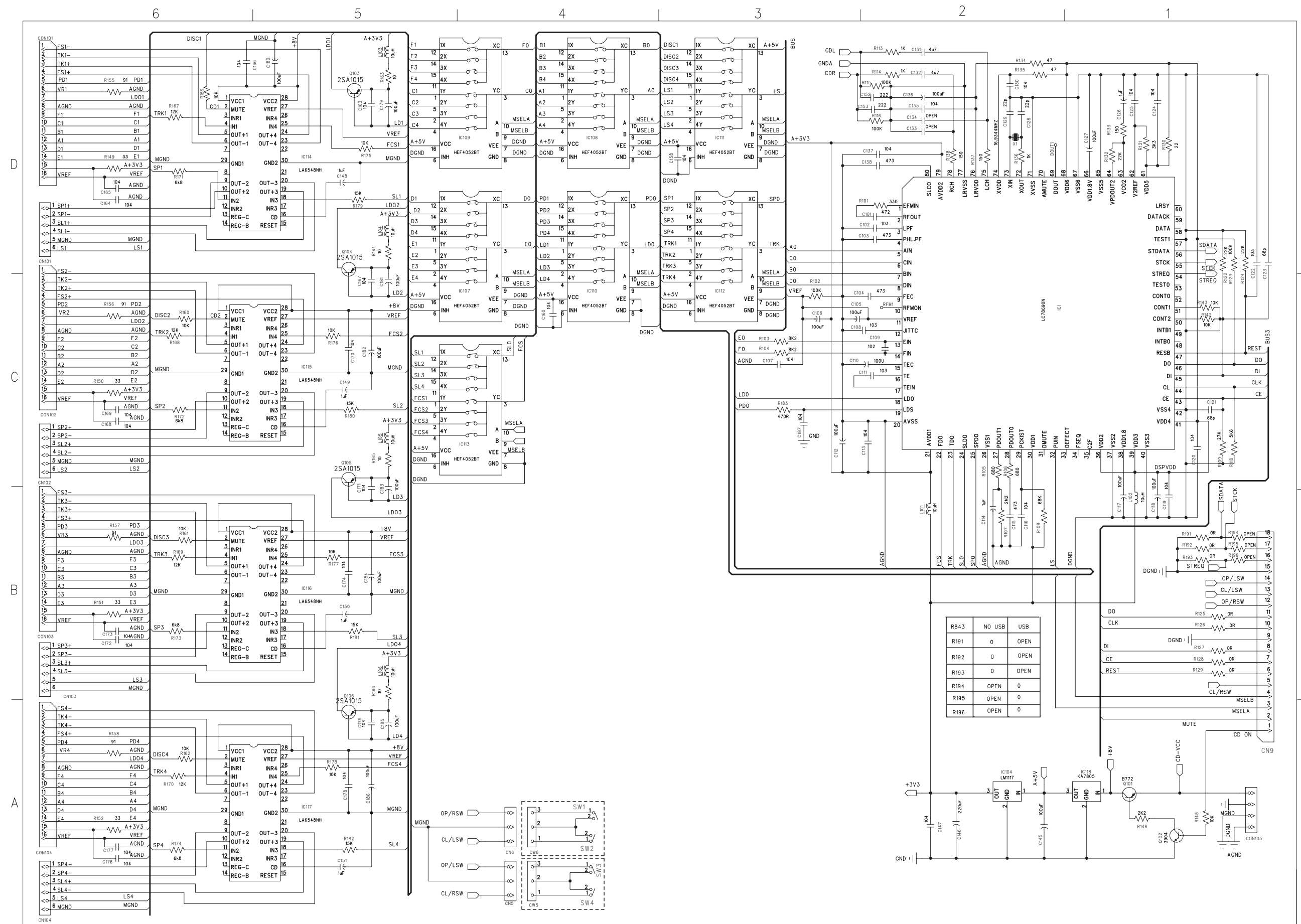

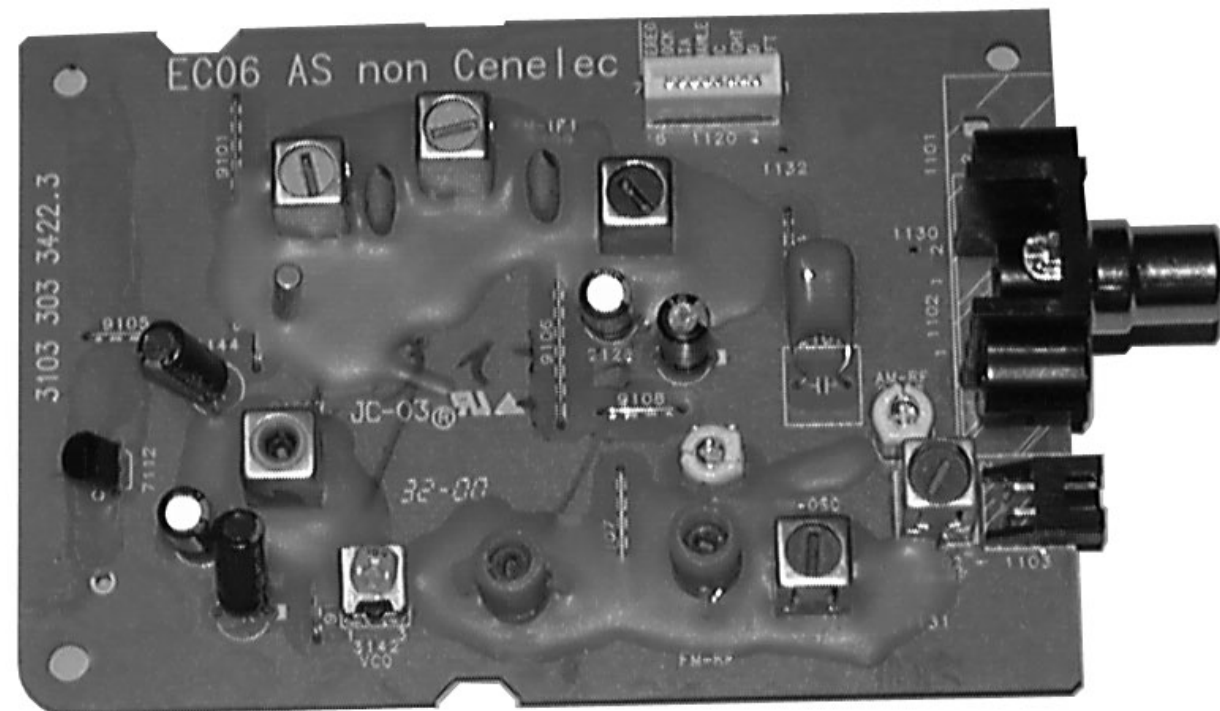

BLOCK DIAGRAM

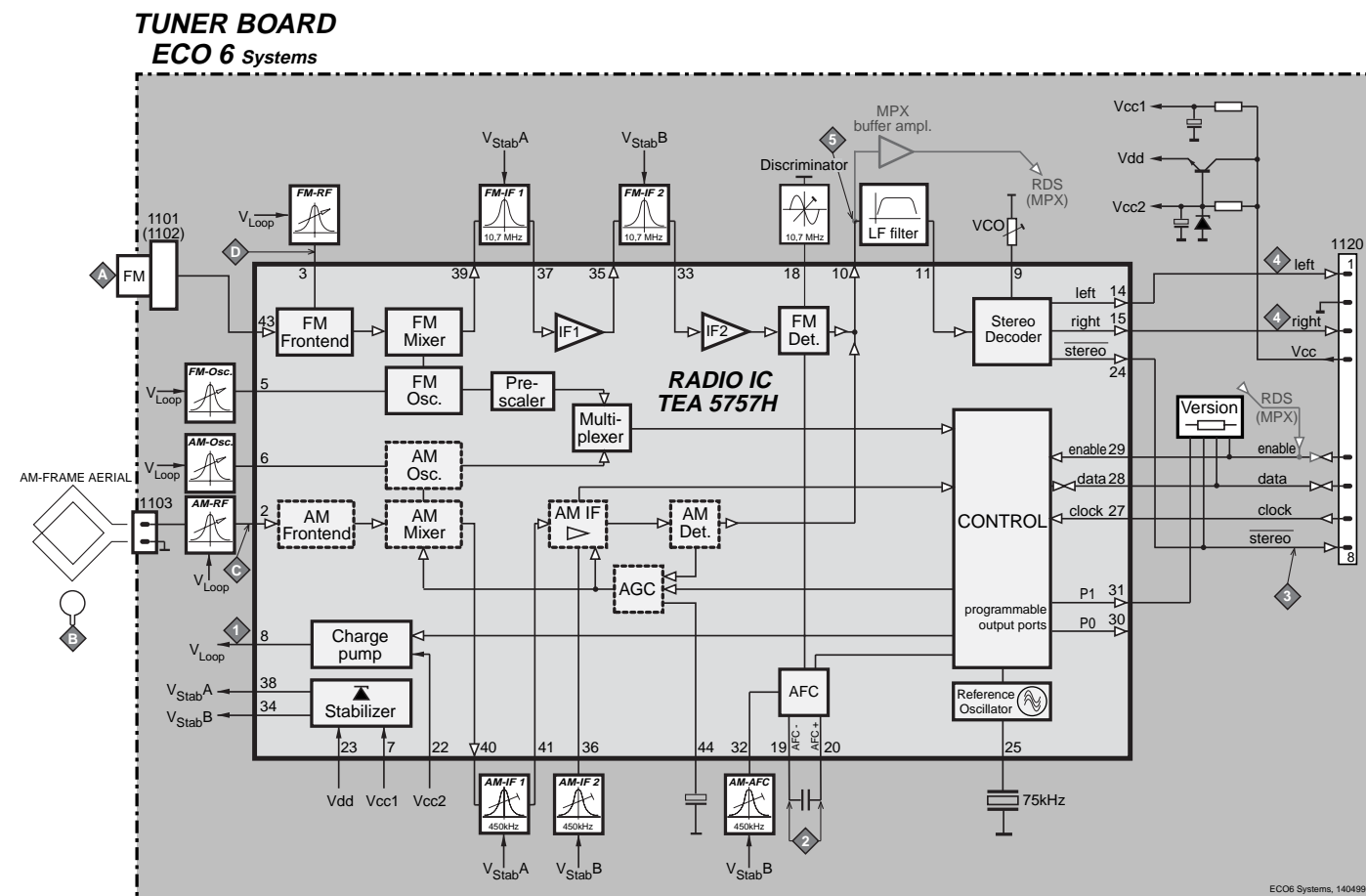

ECO6 Tuner Board
version: **SYSTEMS non-CENELEC**

TABLE OF CONTENTS

Blockdiagram7A-1
 Schematic Diagram7A-2
 Component Layout.....7A-3
 Adjustment table7A-3
 Electrical Partslist7A-4

TUNER BOARD ECO6 / SYSTEMS NON CENELEC

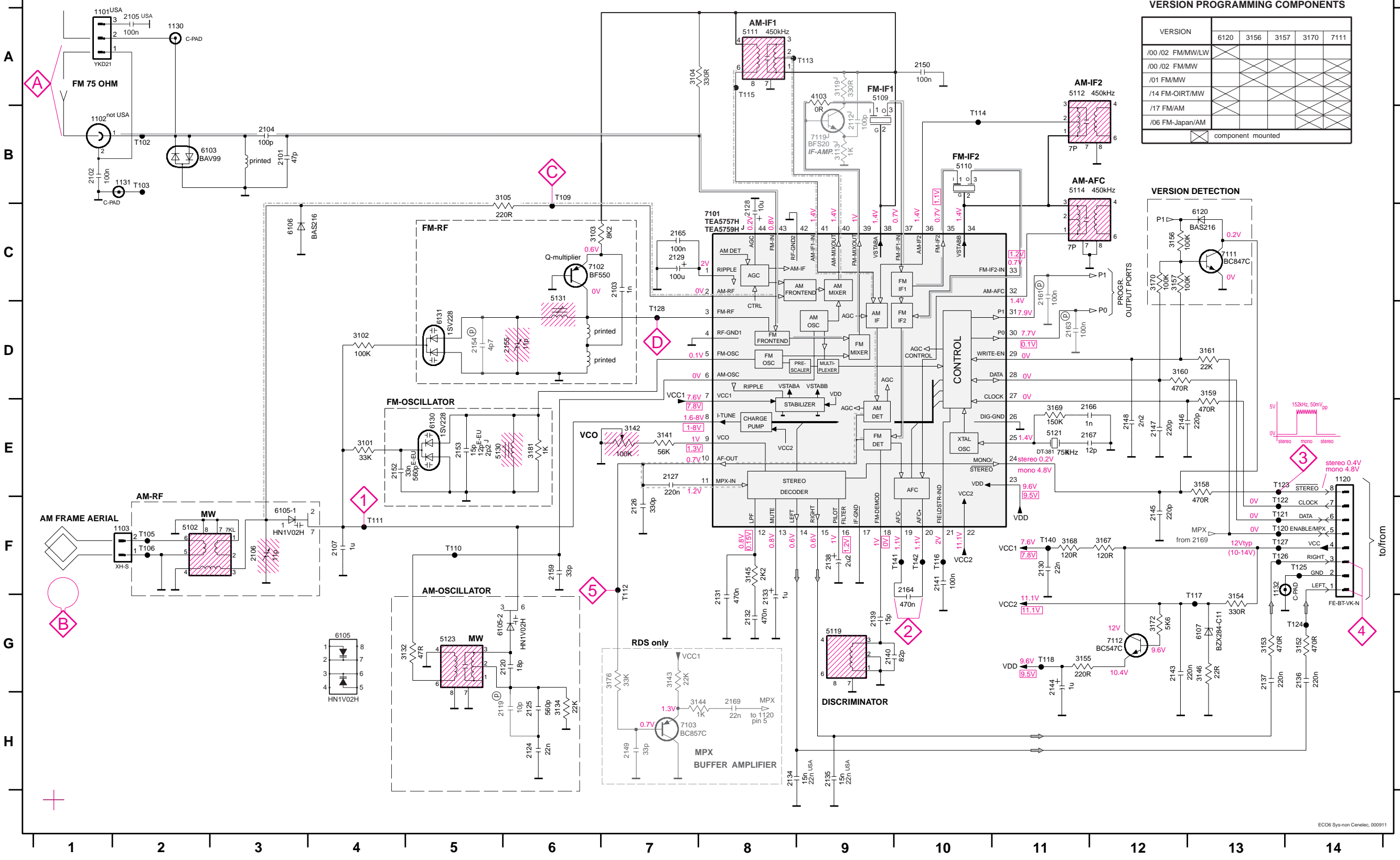

VERSION PROGRAMMING COMPONENTS

VERSION	6120	3156	3157	3170	7111
/00 /02 FM/MW/LW					
/00 /02 FM/MW					
/01 FM/MW					
/14 FM-OIRT/MW					
/17 FM/AM					
/06 FM-Japan/AM					

component mounted

VERSION DETECTION

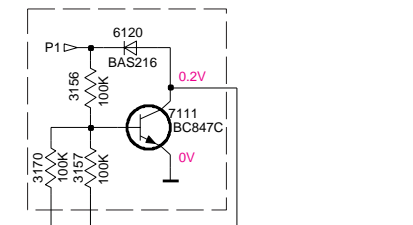

LEGEND

- Ⓢ... for provision only
- USA ... for USA version only
- E-EU ... for East European version only
- J ... for Japanese version only

- ...V FM mode stereo
- ...V MW mode
- ...V LW mode
- voltages measured while set is tuned to a strong transmitter
- EVM

- Signal path
- FM
- - - AM
- · - · MPX (Audio Frequency)
- ⇒ AF - left/right

1101 A1
1102 B1
1103 F2
1120 E14
1130 A2
1131 B2
1132 G13
2101 B3
2102 B1
2103 C7
2104 B3
2105 A2
2106 F3
2107 F4
2119 H6
2120 G6
2124 H6
2125 H6
2126 F7
2127 E7
2128 C8
2129 C7
2130 F11
2131 G8
2132 G8
2133 G8
2134 H8
2135 H6
2136 G14
2137 G13
2138 F9
2139 G9
2140 G9
2141 F10
2143 G12
2144 G11
2145 F12
2146 E12
2147 E2
2148 E12
2149 H7
2150 A10
2152 E4
2153 E5
2154 D5
2155 D5
2159 F6
2161 C11
2163 D11
2164 F10
2165 C7
2166 E11
2167 E11
2169 H8
3101 E4
3102 D4
3103 C6
3104 A7
3105 B6
3132 G5
3134 H6
3141 E7
3142 E7
3143 G7
3144 H7
3145 F8
3146 G14
3152 G14
3153 G13
3154 G13
3155 G11
3156 C12
3157 C12
3158 E13
3159 B13
3160 D12
3161 D13
3167 F12
3168 F11
3169 E11
3170 C12
3172 G12
3176 G7
3181 E6
5102 F2
5109 B9
5110 B10
5111 A8
5112 A11
5114 B11
5119 G9
5121 E11
5123 G5
5130 E5
5131 C6
6103 B2
6105-1 F3
6105-2 G5
6106 C3
6107 G13
6120 C13
6130 E5
6131 D5
7101 C8
7102 C6
7103 H7
7111 C13
7112 G12
T102 B2
T103 B2
T105 F2
T106 F2
T109 B6
T110 F5
T111 F4
T112 F7
T113 A8
T114 B10
T115 A8
T116 B10
T117 G13
T118 G11
T120 F13
T121 F13
T122 F13
T123 E13
T124 G14
T125 F14
T126 F13
T128 D7
T140 F11
T141 F10
T142 F10

1101 A6 1120 A4 1132 A5 2128 C4 2138 C2 3142 D2 5110 B3 5114 A2 5123 D5 7112 C1 9104 B5 9107 D4
 1102 B6 1130 B5 2106 C5 2129 B4 2144 B2 5102 D6 5111 B4 5119 C2 5130 D3 9101 A2 9105 B1 9108 C4
 1103 D6 1131 D5 2107 B5 2133 D2 2155 C4 5109 A3 5112 A3 5121 B2 5131 D4 9103 B2 9106 B3 9109 D2

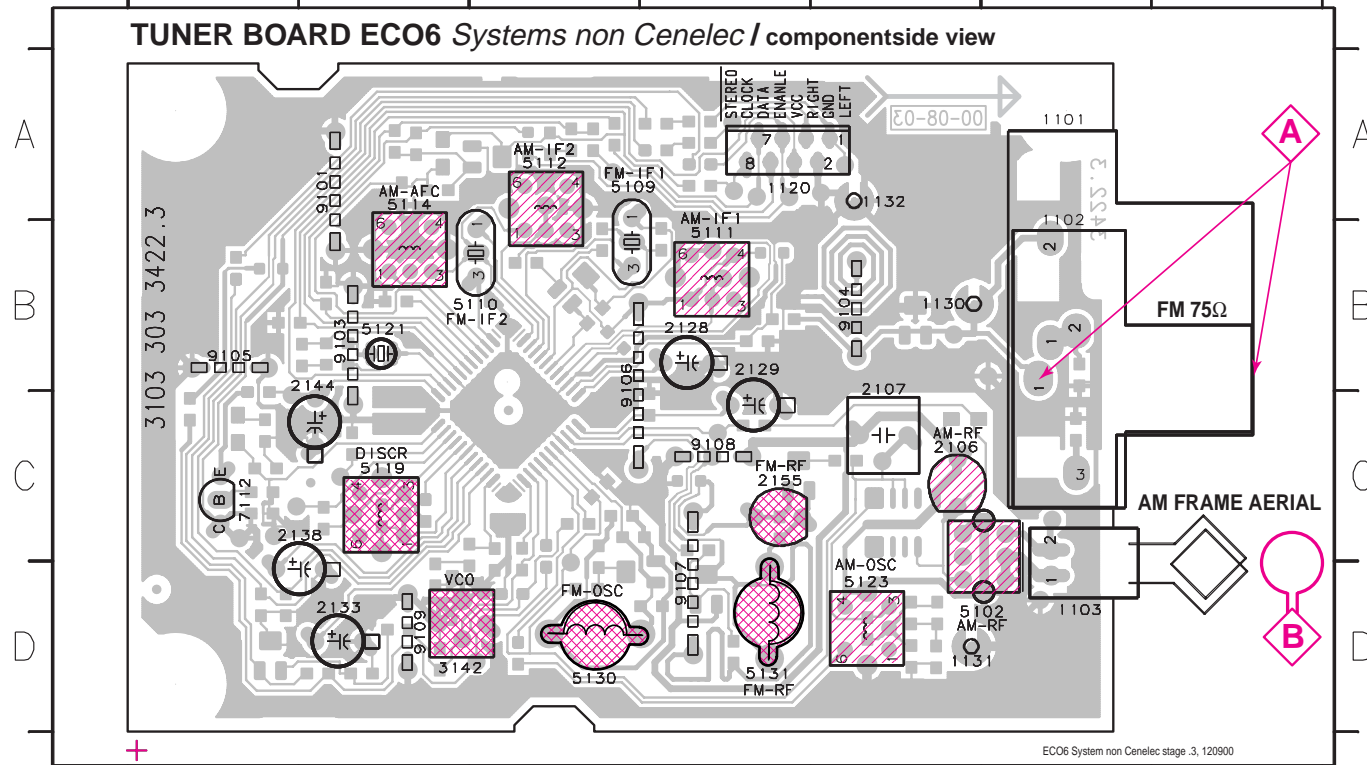

2101 B4 2119 D3 2130 D5 2137 A4 2146 B7 2153 C5 2165 C4 3103 C4 3134 D3 3152 A4 3158 A4 3169 B6 4106 C4 6107 C7 7103 D7
 2102 B1 2120 D3 2131 C5 2139 C6 2147 A5 2154 C4 2166 B6 3104 B4 3141 C5 3153 A4 3159 A5 3170 A6 4107 C5 6120 A6 7111 A5
 2103 D4 2124 D3 2132 D6 2140 C6 2148 B6 2159 C5 2167 B6 3105 C4 3143 D6 3154 C7 3160 A5 3172 C7 4108 C5 6130 D4 7119 B5
 2104 B4 2125 D3 2134 D7 2141 C6 2149 D6 2161 A6 2169 A4 3113 B5 3144 B7 3155 C7 3161 A5 3176 D6 6103 B3 6131 C4
 2105 C1 2126 D6 2135 D7 2143 C7 2150 B5 2163 B6 3101 D5 3119 B5 3145 C5 3156 A6 3167 B7 3181 D4 6105 C3 7101 C5
 2112 B5 2127 C5 2136 A4 2145 A5 2152 C5 2164 C6 3102 C3 3132 D5 3146 C7 3157 A6 3168 C7 4103 B5 6106 C3 7102 D4

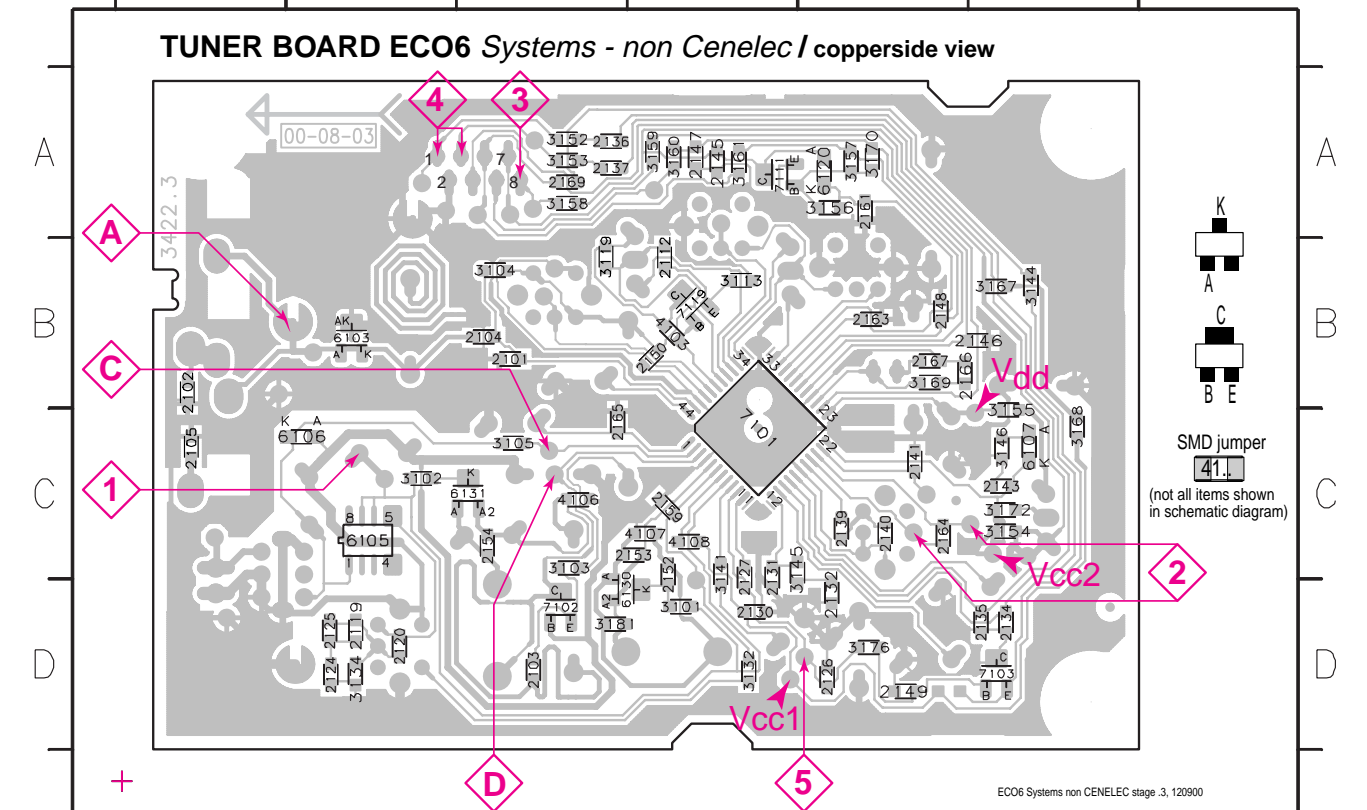

These assembly drawings show a summary of all possible versions.
 For components used in a specific version see schematic diagram respectively partslist.

TUNER ADJUSTMENT TABLE (ECO6 FM/MW- and FM/MW/LW - versions with AM-frame aerial)

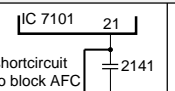
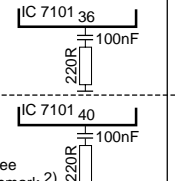
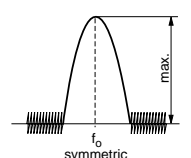
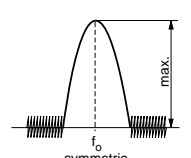
Waverange	Input frequency	Input	Tuned to	Adjust	Output	Scope/Voltmeter
VARICAP ALIGNMENT						
FM 87.5 - 108MHz (65.81 - 74, 87.5 - 108MHz)			108MHz	5130		8V ±0.2V
			87.5MHz (65.81MHz)	check		4.3V ±0.5V (1.2V ±0.5V)
MW FM/AM-version, 10kHz grid 530 - 1700kHz			1700kHz	5123		8V ±0.2V
			530kHz	check		1.1V ±0.4V
FM/MW-version, 9kHz grid 531 - 1602kHz			1602kHz	5123	1	6.9V ±0.2V
			531kHz	check		1.1V ±0.4V
LW 153 - 279kHz			279kHz	5122		8V ±0.2V
			153kHz	check		1.1V ±0.4V
MW FM/MW/LW- version, 9kHz grid 531 - 1602kHz			1602kHz	5123		8V ±0.2V
			531kHz	check		1.1V ±0.4V
FM IF						
FM	10.7MHz, 45mV continuous wave	D		5119	2	0 ± 3 mV DC
FM RF						
FM 87.5 - 108MHz (65.81 - 74, 87.5 - 108MHz)	108MHz	A	108MHz	2155	4	MAX
	87.5MHz (65.81MHz)	mod=1kHz Δf=±22.5kHz	87.5MHz (65.81MHz)	5131		
VCO						
FM	98MHz, 1mV continuous wave	A	98MHz	3142	3	152kHz ±1kHz ¹⁾
AM IF						
MW	450kHz connect pin 6 of IC 7101 (AM Osc.) with 3.3kΩ to Vcc	C Δf=±10kHz V _{RF} = 0.5mV (as low as possible)		5111	5	
				5112		
AM AFC		C		5114	2	0 ± 2 mV DC
AM RF³⁾						
MW⁴⁾ FM/MW/LW- and FM/MW-version (9kHz grid) 531 - 1602kHz	1494kHz	B	1494kHz	2106	5	
	558kHz		558kHz	5102		
LW	198kHz		198kHz	5103		
MW FM/AM-version, 10kHz grid 530 - 1700kHz	1500kHz	Δf = ±30kHz V _{RF} as low as possible	1500kHz	2106		
	560kHz		560kHz	5102		

Use Service Testprogram. By selecting the TUNER TEST test frequencies will be stored as preset frequencies automatically.
¹⁾ If sensitivity of frequency counter is too low adjust to max. channel separation (input signal: stereo left 90% + 9%, adjust output on right channel to minimum)
²⁾ RC network serves for damping the IF-filter while adjusting the other one.
³⁾ For AM RF adjustments the original frame antenna has to be used!
⁴⁾ MW has to be aligned before LW.
 ↑ Repeat

SUBWOOFER AMP BOARD

TABLE OF CONTENTS

PCB - Layout (Top).....	8-2
PCB - Layout (Bottom)	8-2
PCB - Circuit Diagram	8-4

PCB LAYOUT - SUB AMP BOARD (BOTTOM VIEW)

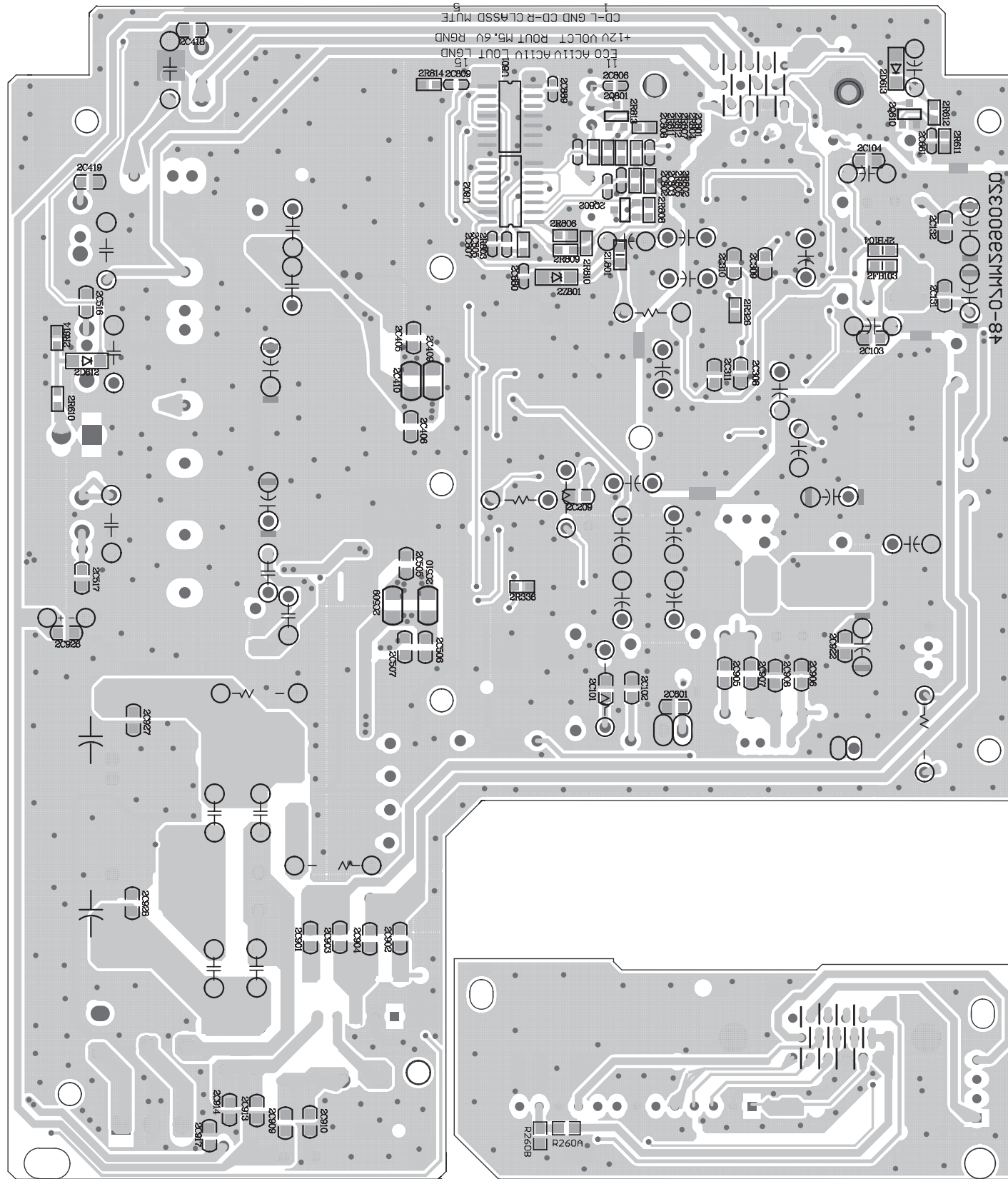

CIRCUIT DIAGRAM - SUB AMP BOARD

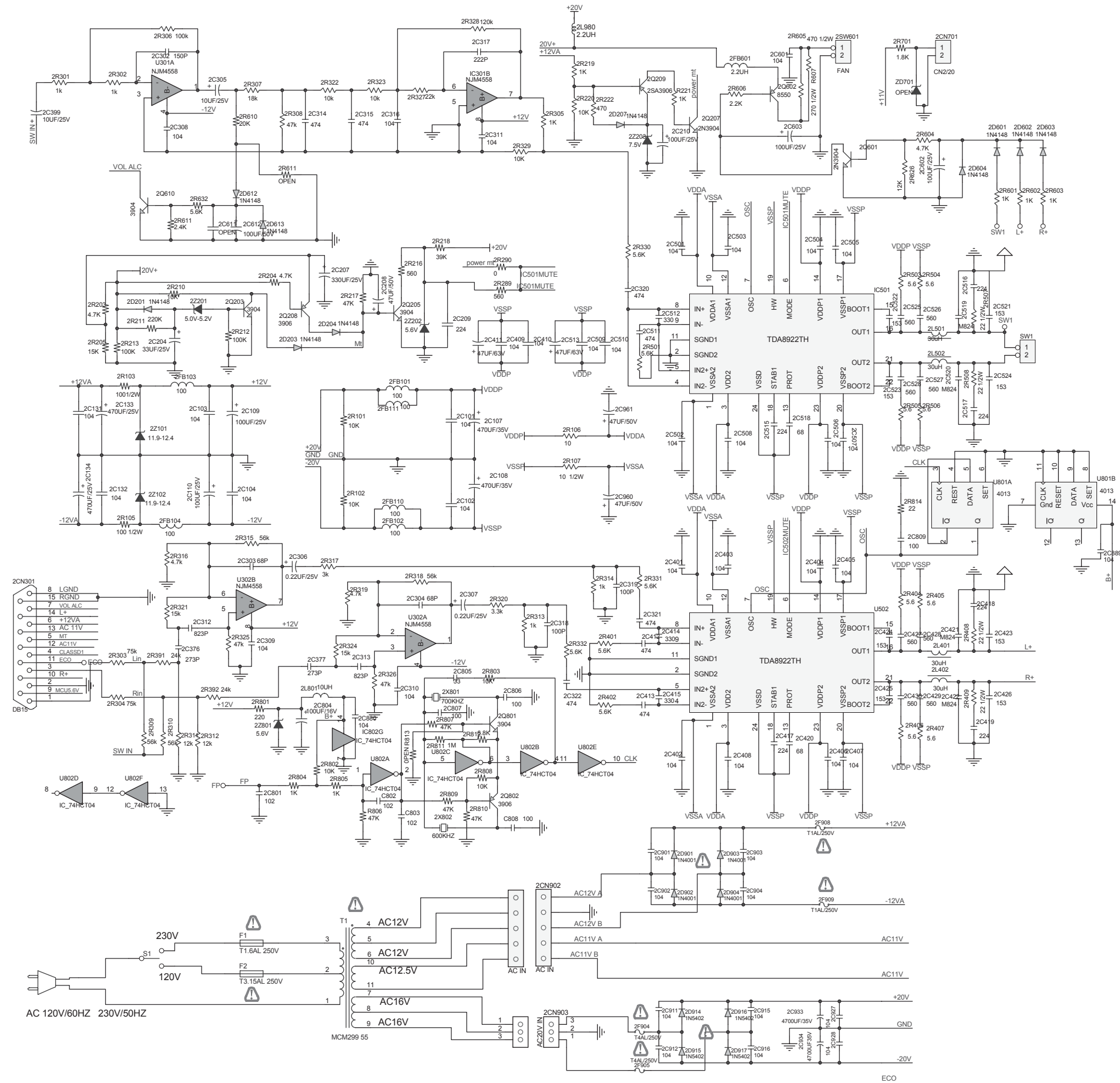

FTD DISPLAY PIN CONNECTION

DISPLAY BOARD

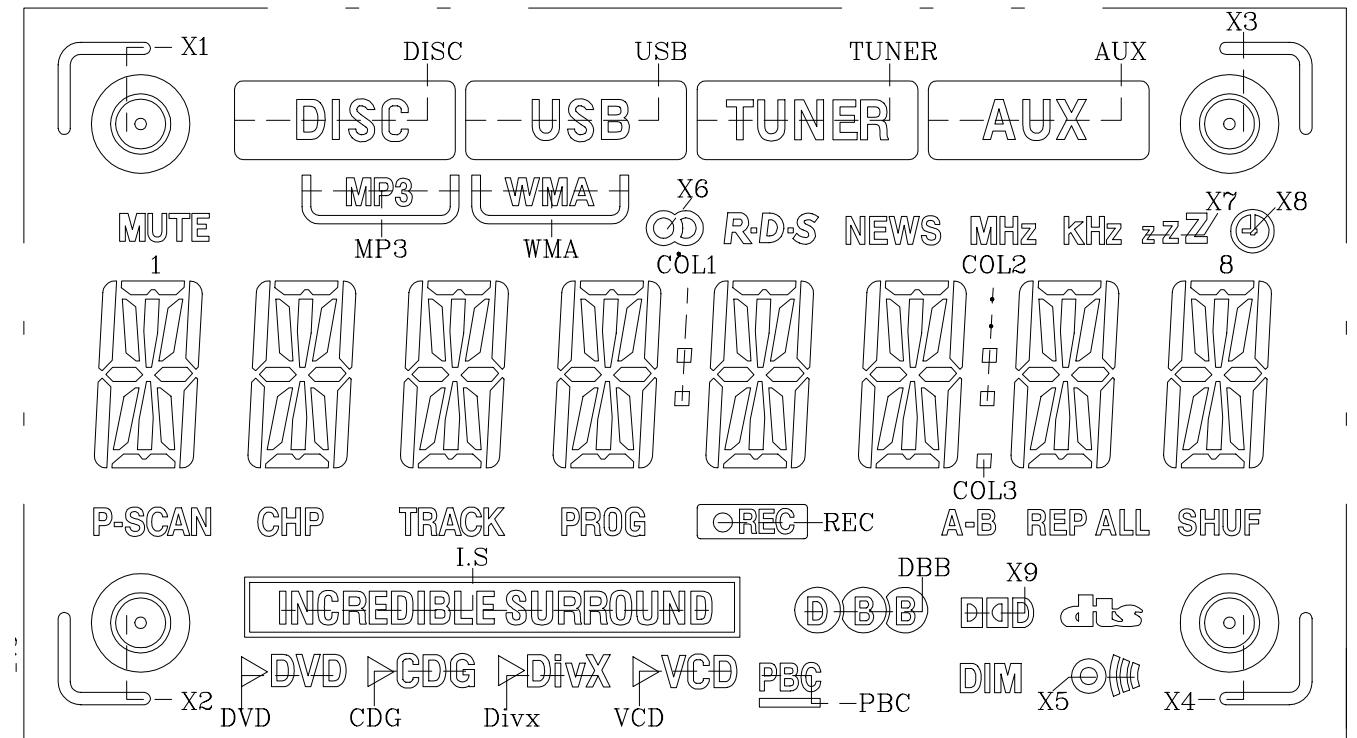
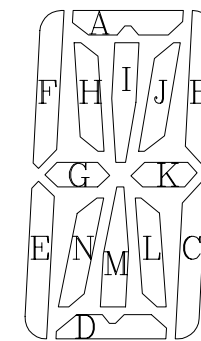

TABLE OF CONTENTS

FTD Display Pin Connection 9-1
 Display PCB - Layout Top View 9-2
 Display PCB - Layout Bottom View 9-3
 Display PCB - Circuit Diagram 9-4



PIN	1	2	3	4	5	6	7	8	9	10	11	12	13	14	15	16	17
IC NO.	COM0	COM1	COM2	COM3	COM4	COM5	COM6	COM7	SEGO	SEG1	SEG2	SEG3	SEG4	SEG5	SEG6	SEG7	SEG8
COM0	COM0								X1	USB	WMA	CDG	PBC	Divx	TRACK	COL1	DBB
COM1		COM1							MUTE	1A	1B	2A	2B	3A	3B	4A	4B
COM2			COM2						X2	1I	1J	2I	2J	3I	3J	4I	4J
COM3				COM3					DISC	1F	1H	2F	2H	3F	3H	4F	4H
COM4					COM4				MP3	1G	1K	2G	2K	3G	3K	4G	4K
COM5						COM5				1L	1C	2L	2C	3L	3C	4L	4C
COM6							COM6		DVD	1N	1M	2N	2M	3N	3M	4N	4M
COM7								COM7	VCD	1E	1D	2E	2D	3E	3D	4E	4D

PIN	18	19	20	21	22	23	24	25	26	27	28
IC NO.	SEG9	SEG10	SEG11	SEG12	SEG13	SEG14	SEG15	SEG16	SEG17	SEG18	SEG19
COM0	TUNER	X5	DIM	PROG	AUX	MHz	kHz	A-	B	SHUF	P-SCAN
COM1	5A	5B	6A	6B	7A	7B	8A	8B	dtS	X4	CHP
COM2	5I	5J	6I	6J	7I	7J	8I	8J			REC
COM3	5F	5H	6F	6H	7F	7H	8F	8H	X7	COL2	I.S
COM4	5G	5K	6G	6K	7G	7K	8G	8K	X8	COL3	R-D-S
COM5	5L	5C	6L	6C	7L	7C	8L	8C	X3	X6	NEWS
COM6	5N	5M	6N	6M	7N	7M	8N	8M	REP	X9	
COM7	5E	5D	6E	6D	7E	7D	8E	8D	ALL		

PCB LAYOUT - DISPLAY BOARD (TOP VIEW)

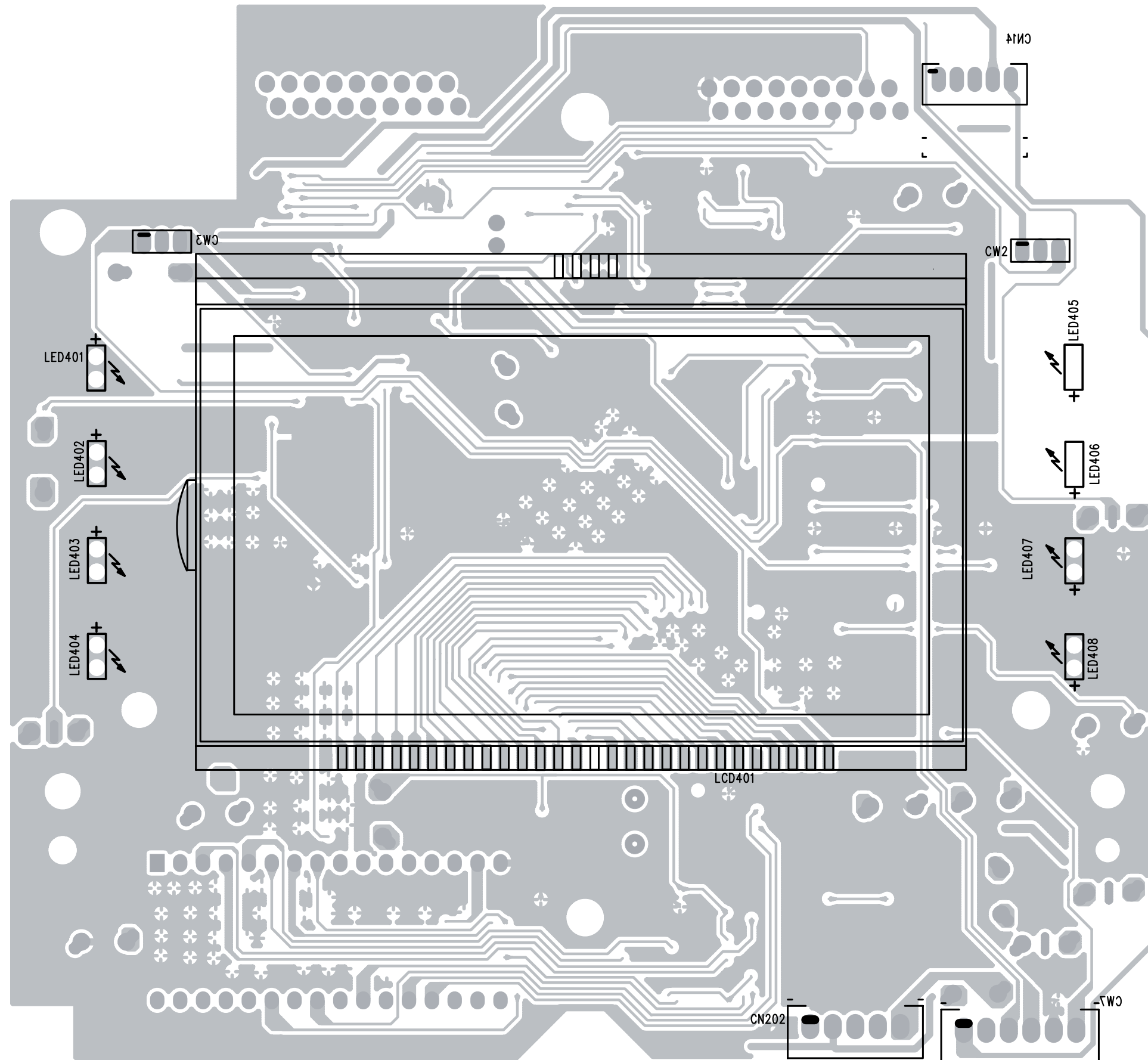

CIRCUIT DIAGRAM - DISPLAY BOARD

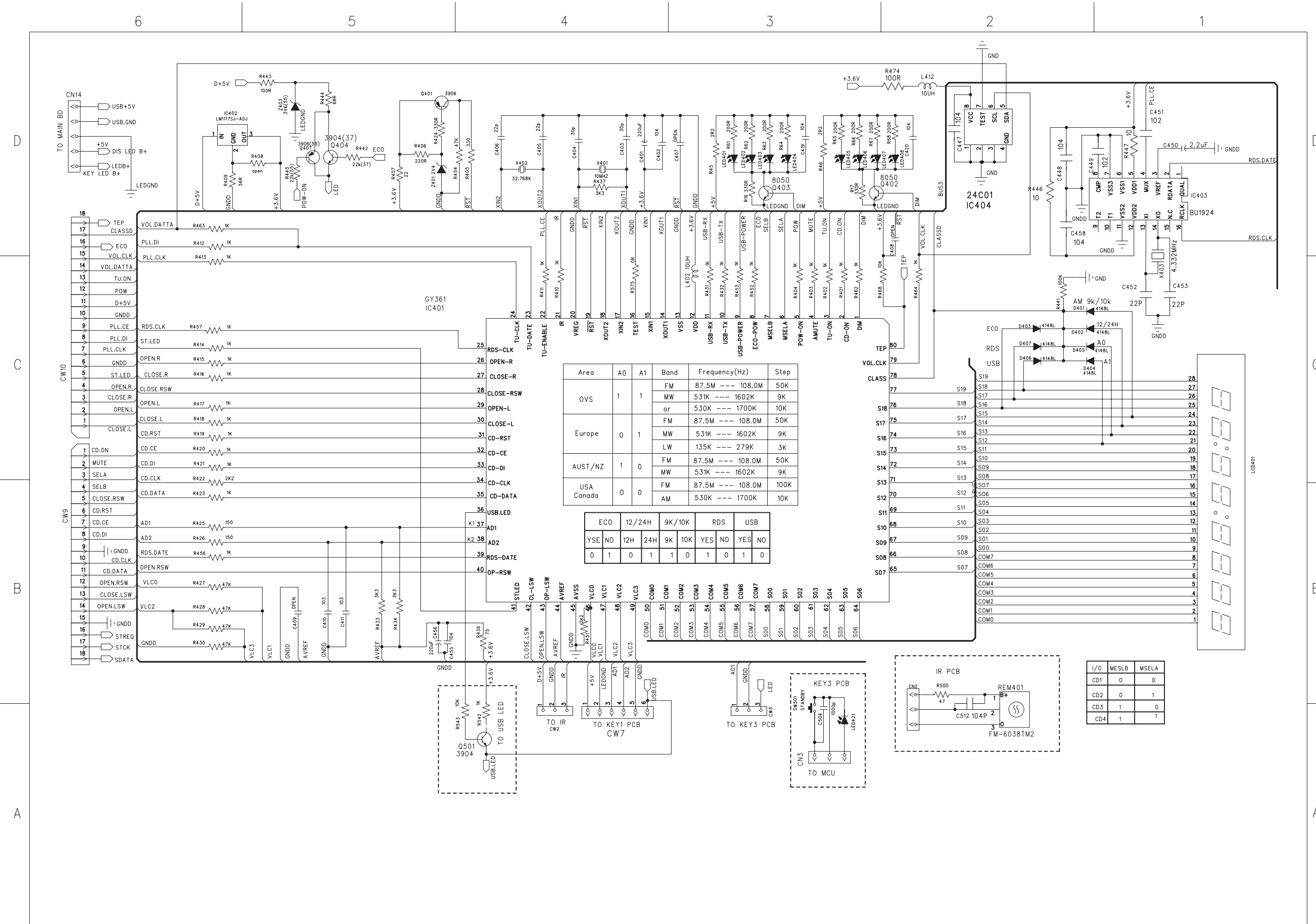

KEY BOARD

TABLE OF CONTENTS

KEY1 PCB - Layout Top View	10-2
KEY1 PCB - Circuit Diagram Part	10-2
KEY2 PCB - Layout Top View	10-3
KEY2 PCB - Circuit Diagram Part	10-3

PCB LAYOUT - KEY1 BOARD (TOP VIEW)

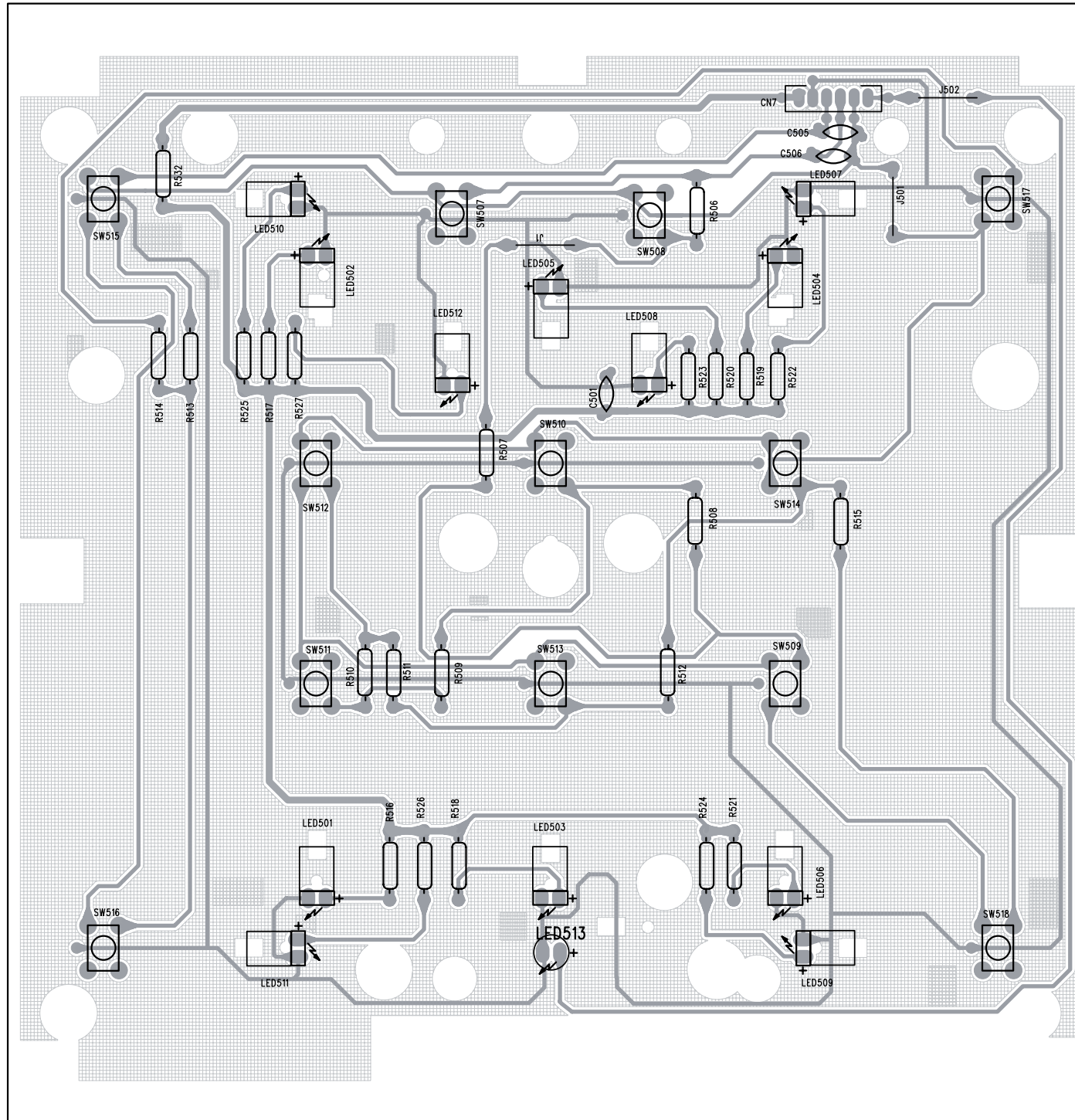

CIRCUIT DIAGRAM - KEY1 BOARD

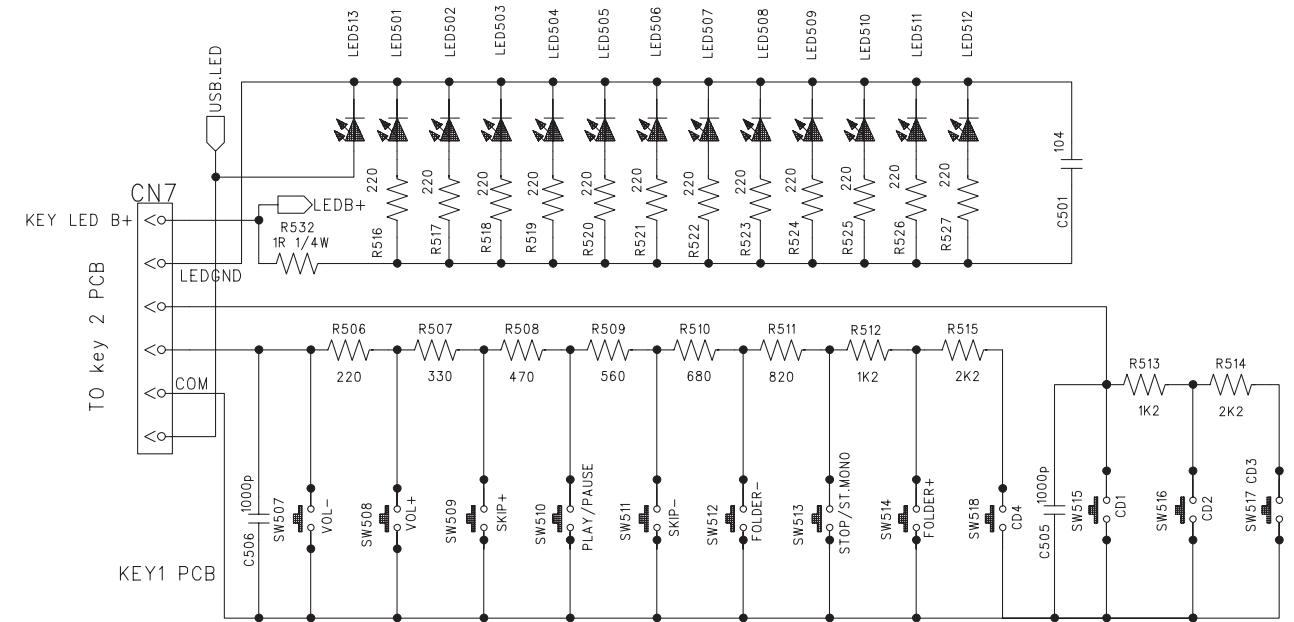

PCB LAYOUT - KEY2 BOARD

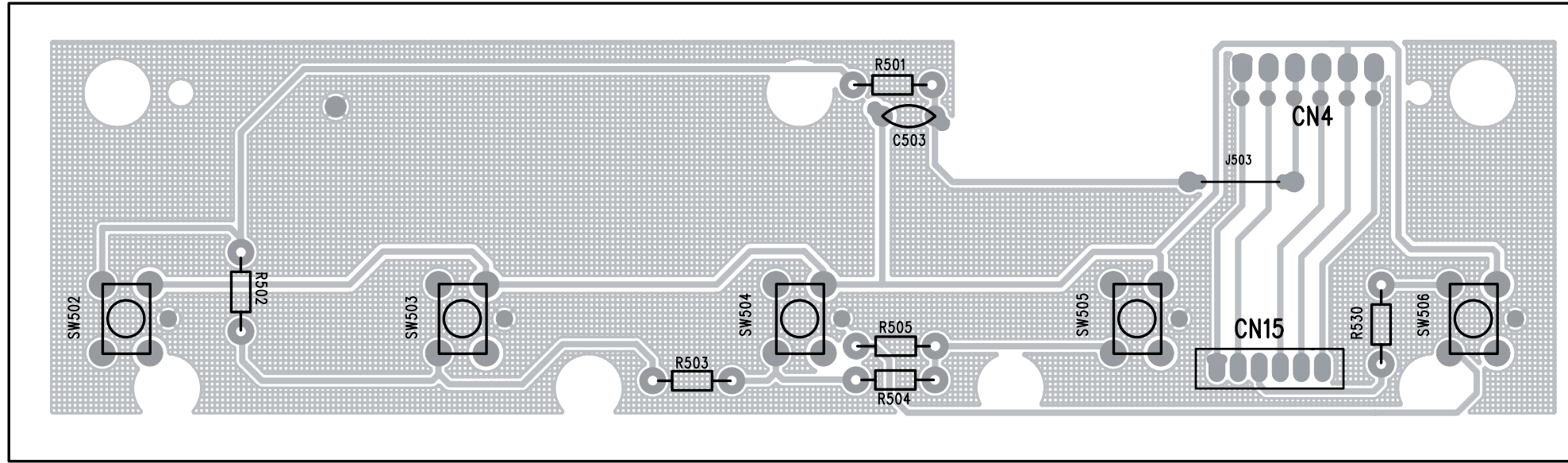

CIRCUIT DIAGRAM - KEY2 BOARD

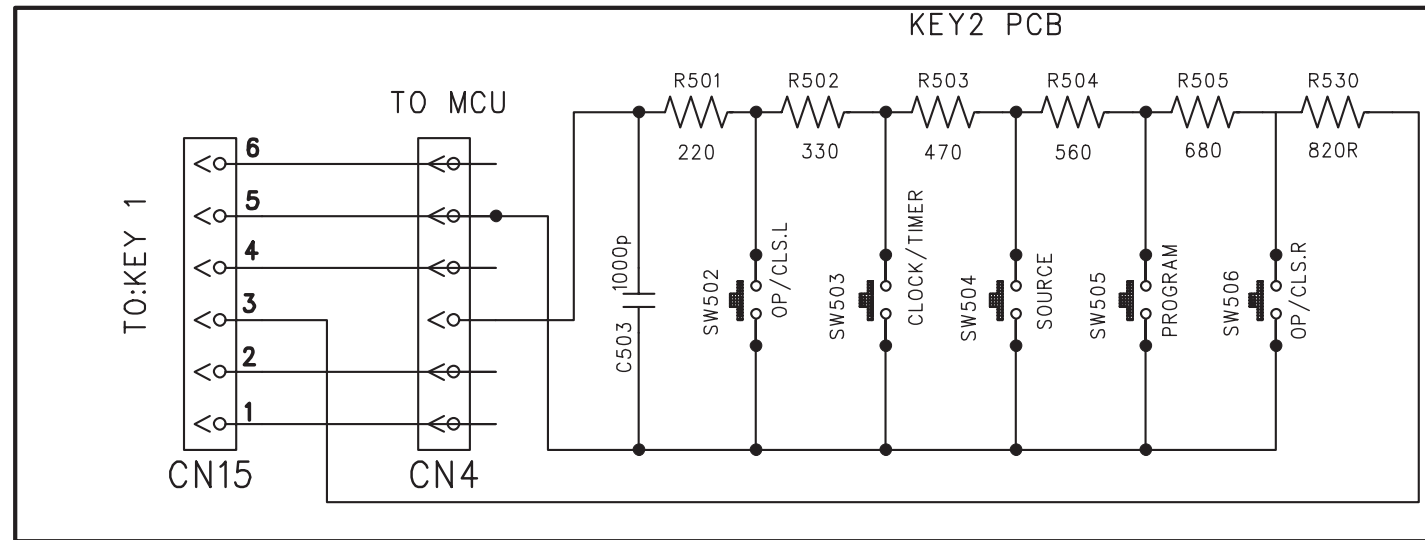

MAIN SET MECHANICAL EXPLODED VIEW

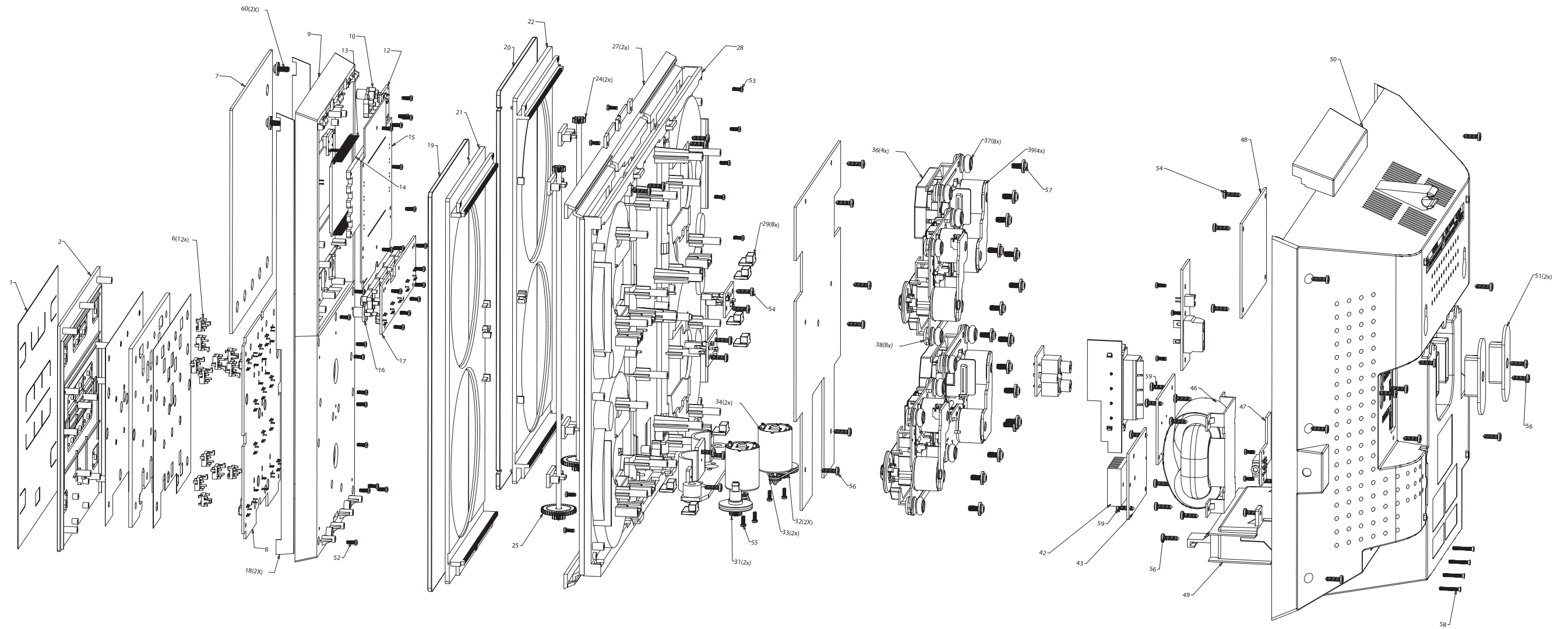

SUBWOOFER MECHANICAL EXPLODED VIEW

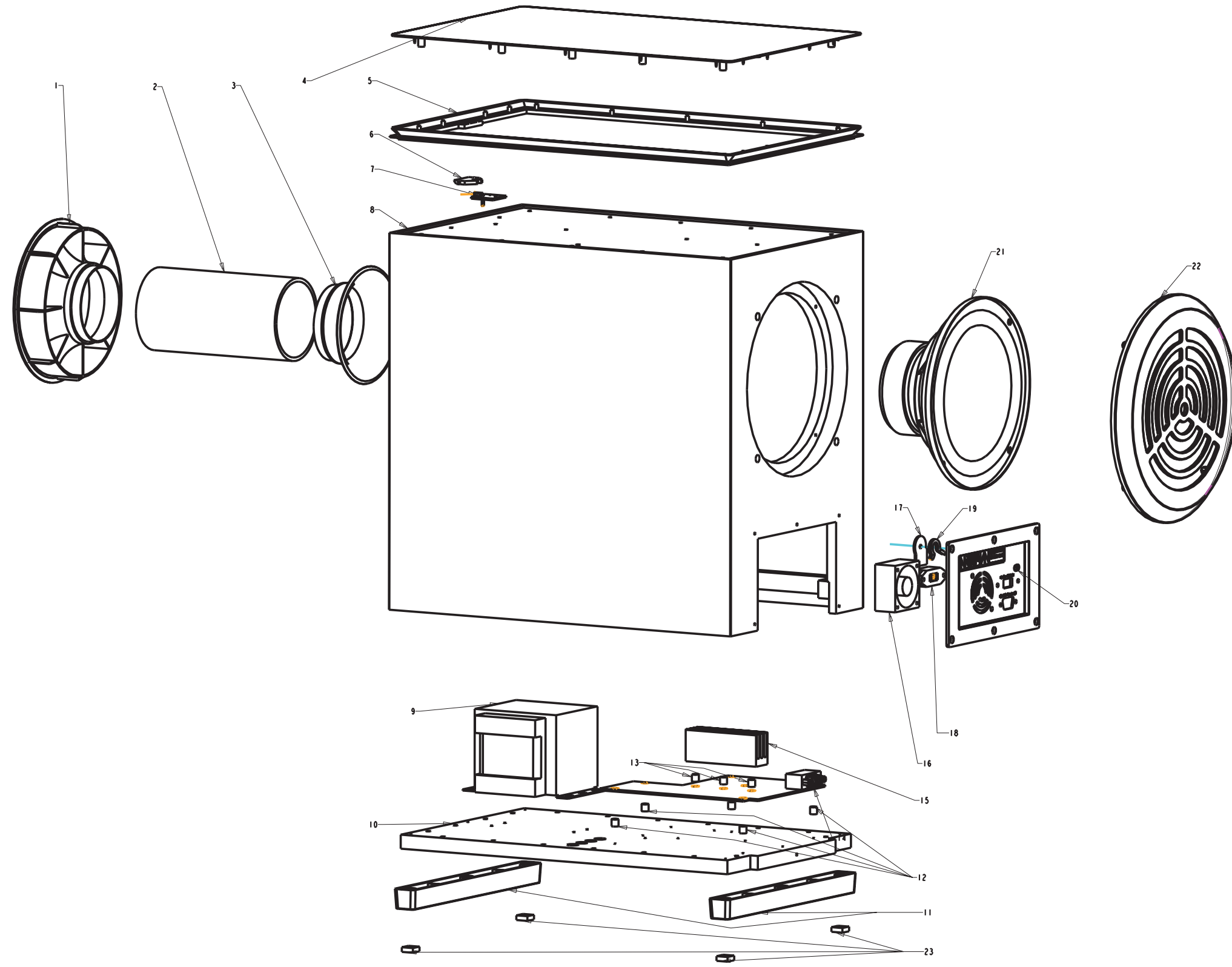

MAIN UNIT MECHANICAL & ACCESSORIES PARTS LIST

02	9965 000 40380	CONTROL PANEL	9940 000 02823	AM/FM ANT (75R) ASS'Y PACKING
07	9965 000 42426	FRONT LENS	9940 000 04392	LASER COVER (FOR SANYO CD)
09	9965 000 40378	FRONT PANEL	9965 000 40091	MAIN SET STAND ASSEMBLY
10	9965 000 40388	STAND KEY	9965 000 40092	SPEAKER STAND ASSEMBLY
16	9965 000 40389	SOURCE KEY	9965 000 40376	REMOTE CONTROL
19	9965 000 40393	CD DOOR LENS-R	9965 000 40382	WALL BRACKET
20	9965 000 40392	CD DOOR LENS -L	9965 000 40390	SCREW SPACE (RED)
21	9965 000 40384	CD DOOR RIGHT	9965 000 40398	SELF-TAPPING SCREW 4.6X30MM
22	9965 000 40383	CD DOOR LEFT	9965 000 40405	16P FFC 1MM L=60MM
24	9965 000 40386	ROLLER TOP GEAR	9965 000 40406	15P FFC 1.25MM L=130MM
25	9965 000 40385	ROLLER BOTTOM GEAR	9965 000 40407	18P FFC 1.25MM L=130MM
27	9965 000 42424	CD DOOR TRACK	9965 000 42419	SPK BOX ASS'Y (L)
28	9965 000 42422	MIDDLE PANEL	9965 000 42420	SPK BOX ASS'Y (R)
29	9965 000 40397	CD DAMPER	9965 000 42421	15P CABLE L=2000MM
31	9965 000 40387	DRIVER PULLEY	9965 000 42425	SPK GRILL
32	9965 000 40395	BELT 29.5X1.3X1.3MM		
33	9940 000 02818	DOOR MOTOR PULLY		
34	△ 9940 000 02815	DC MOTOR 5V		
37	9940 000 01944	DAMPER-RUBBER (30C)		
38	9965 000 40396	DAMPER-RUBBER (50C)		
39	9940 000 05398	CD MECHANISM DA11B3VF		
50	9965 000 42423	REAR PANEL		

Note: Only these parts mentioned in the list are normal service parts.

SUBWOOFER MECHANICAL & ACCESSORIES PARTS LIST

04	9965 000 42454	TOP COVER
09	△ 9965 000 42446	TRANSFORMER EI76X40 120/230V
11	9965 000 42451	SUB STAND
16	△ 9965 000 42455	FAN JD4020L-S110 5000R/MIN
18	9965 000 39376	SWITCH SL14-22AH-5AN
19	△ 9965 000 40325	AC CORD VDE APP 6FT (BLK)
20	9965 000 42453	REAR PLATE
21	9965 000 42447	SUBWOOFER SPK 6R 60W
22	9965 100 01559	SUB GRILL
23	9940 000 01264	FOOT RUBBER 4MM
	9965 000 42448	CLOSE END WIRE CONNECTOR
	△ 9965 000 42449	GLASS FUSE 5X20MM T1.6AL 250V
	△ 9965 000 42450	GLASS FUSE 5X20MM T3.15AL/250V

Note: Only these parts mentioned in the list are normal service parts.

ELECTRICAL PARTS LIST - MAIN BOARD

C133	9965 000 42428	E.CAP 1000UF 16V -20%	Q610	9965 000 38609	TRANSISTORS 2W 8050C
C314	9965 000 42429	E.CAP 6800UF 25V -20%	Q611	9965 000 38609	TRANSISTORS 2W 8050C
C640	9965 000 42428	E.CAP 1000UF 16V -20%	Q613	9940 000 04338	TRANSISTORS PMBT3904
C725	9965 000 42428	E.CAP 1000UF 16V -20%	Q708	9940 000 04337	TRANSISTORS 2SD1936T-AC
F302	△ 9940 000 00585	CERAMIC FUSE W/LEAD 2A/250V	Q709	9940 000 04337	TRANSISTORS 2SD1936T-AC
IC1	9965 000 39807	IC (SANYO) LC78690NW-E	SPK1	9940 000 01219	SPK JACK (RD/BLK/BLK/RD)
IC104	9940 000 02839	IC H1117SJ-3.3V	U702	5322 209 15853	NJM4556AM
IC107	9940 000 04344	IC HEF4052BT	X1	9940 000 04551	CRYSTAL 16,9344MHZ -20PPM
IC108	9940 000 04344	IC HEF4052BT			
IC109	9940 000 04344	IC HEF4052BT			
IC110	9940 000 04344	IC HEF4052BT			
IC111	9940 000 04344	IC HEF4052BT			
IC112	9940 000 04344	IC HEF4052BT			
IC113	9940 000 04344	IC HEF4052BT			
IC114	9940 000 04622	IC LA6548NH			
IC115	9940 000 04622	IC LA6548NH			
IC116	9940 000 04622	IC LA6548NH			
IC117	9940 000 04622	IC LA6548NH			
IC118	9940 000 04549	IC KA7805E			
IC601	9322 150 74668	IC SM TDA7468D (ST00) R			
IC603	9940 000 00253	IC (SAMSUNG) KA7808			
IC702	9940 000 00253	IC (SAMSUNG) KA7808			
IC801	4822 209 30619	TA7291S			
IC802	4822 209 30619	TA7291S			
IC803	9940 000 00253	IC (SAMSUNG) KA7808			
JK1	9940 000 04369	PHONE JACK TC38-063-05-01			
JK2	9940 000 01353	COAXIAL JACK IF-01A			
JK4	9965 000 39811	H/RCA JACK 2P (WH/RD)			
L101	9965 000 42430	CHIP INDUCTOR 10UH 1.85R			
L102	9965 000 42430	CHIP INDUCTOR 10UH 1.85R			
L103	9965 000 42430	CHIP INDUCTOR 10UH 1.85R			
L104	9965 000 42430	CHIP INDUCTOR 10UH 1.85R			
L105	9965 000 42430	CHIP INDUCTOR 10UH 1.85R			
L106	9965 000 42430	CHIP INDUCTOR 10UH 1.85R			
Q101	9940 000 01193	TRANSISTORS KSB772YS			
Q102	9940 000 04338	TRANSISTORS PMBT3904			
Q103	9965 000 42427	TRANSISTORS 2SA1015GR			
Q104	9965 000 42427	TRANSISTORS 2SA1015GR			
Q105	9965 000 42427	TRANSISTORS 2SA1015GR			
Q106	9965 000 42427	TRANSISTORS 2SA1015GR			
Q603	9940 000 04144	PNP TRANSISTORS 9015C			
Q604	9940 000 04144	PNP TRANSISTORS 9015C			
Q605	9940 000 04338	TRANSISTORS PMBT3904			
Q608	9940 000 04338	TRANSISTORS PMBT3904			
Q609	9940 000 01193	TRANSISTORS KSB772YS			

Note: Only these parts mentioned in the list are normal service parts.

ELECTRICAL PARTS LIST - TUNER BOARD

2106	9940 000 00254	TRIMMER 10PF 6MM (WH)
2155	9940 000 00254	TRIMMER 10PF 6MM (WH)
5102	9940 000 01212	AM IFT (BLACK) 7MM
7101	9351 740 80557	IC SM TEA5757H/V1 (PHSE) Y
6130	9940 000 01479	VARICAP DIODE ISV228
6131	9940 000 01479	VARICAP DIODE ISV228
6105	9940 000 02454	VARIABLE CAP DIODE HN-1V02H
5130	9940 000 03653	BOBBIN COIL WHITE 1 1/2T
5131	9940 000 03653	BOBBIN COIL WHITE 1 1/2T
5121	9940 000 04352	CRYSTAL 75KHZ 12.5PF DT-381
5109	9940 000 04536	CER. FILTER SFE10,7MJA10-A 3P
5110	9940 000 04536	CER. FILTER SFE10,7MJA10-A 3P
6107	9965 000 42431	ZENER DIODE 11V PDZ11B
3142	9965 000 42432	SEMI-FIXED 6MM 100KB
5119	9965 000 42433	I.F.T 7MM KS2599 (BLK)
5112	9965 000 42434	I.F.T 7MM C712KC-004 (YEL)
5114	9965 000 42434	I.F.T 7MM C712KC-004 (YEL)
5123	9965 000 42435	I.F.T 7MM 7M1A2146 (BROWN)
5111	9965 000 42436	I.F.T 7MM 7M4A2011N (BLACK)

Note: Only these parts mentioned in the list are normal service parts.

ELECTRICAL PARTS LIST - SUBWOOFER AMP BOARD

2Q602	9965 000 38610	TRANSISTORS 2W 8550C
2Q205	9940 000 04338	TRANSISTORS PMBT3904
2Q203	9940 000 04338	TRANSISTORS PMBT3904
2Q207	9940 000 04338	TRANSISTORS PMBT3904
2Q601	9940 000 04338	TRANSISTORS PMBT3904
2Q610	9940 000 04338	TRANSISTORS PMBT3904
2Q208	9940 000 03937	TRANSISTORS PMBT3906
2Q209	9940 000 03937	TRANSISTORS PMBT3906
2Q802	9940 000 03937	TRANSISTORS PMBT3906
2D201	9940 000 04363	DIODE PMLL4148L
2D203	9940 000 04363	DIODE PMLL4148L
2D207	9940 000 04363	DIODE PMLL4148L
2D204	9940 000 04363	DIODE PMLL4148L
2D604	9940 000 04363	DIODE PMLL4148L
2D612	9940 000 04363	DIODE PMLL4148L
2D613	9940 000 04363	DIODE PMLL4148L
2D601	9965 000 42437	CH-DIODE SS14 SMA/DO-214AC
2D602	9965 000 42437	CH-DIODE SS14 SMA/DO-214AC
2D603	9965 000 42437	CH-DIODE SS14 SMA/DO-214AC
U802	9965 000 42456	IC 74HCT04D SOP14
U801	9965 000 42457	IC HEF4013BT
U501	9965 000 42458	IC TDA8922BTH
U502	9965 000 42458	IC TDA8922BTH
U301	9965 000 39809	IC YD4558
U302	9965 000 39809	IC YD4558
2C933	9965 000 42459	E.CAP 4700UF 35V -20% (PH)
2C934	9965 000 42459	E.CAP 4700UF 35V -20% (PH)
2X801	9965 000 42460	CERAMIC RESONATOR 600KHZ
2X802	9965 000 42461	CERAMIC RESONATOR 700KHZ
2FB101	9965 000 42462	FXDIND BEAD 100MHZ 80R
2FB102	9965 000 42462	FXDIND BEAD 100MHZ 80R
2FB110	9965 000 42462	FXDIND BEAD 100MHZ 80R
2FB111	9965 000 42462	FXDIND BEAD 100MHZ 80R
2CN301	9965 000 42463	D-SUB CONNECTOR
2CN302	9965 000 42463	D-SUB CONNECTOR
2F908	\$ 9965 000 42464	AXIAL FUSE 3.9X10.5MM T1A/250V
2F909	\$ 9965 000 42464	AXIAL FUSE 3.9X10.5MM T1A/250V
2F904	\$ 9965 000 42465	AXIAL FUSE 3.9X10.5MM T1A/250V
2F905	\$ 9965 000 42465	AXIAL FUSE 3.9X10.5MM T1A/250V

Note: Only these parts mentioned in the list are normal service parts.

ELECTRICAL PARTS LIST - SUBWOOFER LED BOARD

9965 000 42443 LED LAMP 2X5X7MM(S.BLUE)

Note: Only these parts mentioned in the list are normal service parts.

ELECTRICAL PARTS - DISPLAY BOARD

D402	9940 000 04363	DIODE PMLL4148L
D403	9940 000 04363	DIODE PMLL4148L
D404	9940 000 04363	DIODE PMLL4148L
D405	9940 000 04363	DIODE PMLL4148L
D409	9965 000 42437	DIODE SS14 SMA/DO-214AC
IC401	9965 000 42440	MCU GY372U -USA (OTP)
IC402	9940 000 02839	IC H1117SJ-3.3V
IC404	9940 000 04541	IC M24C02-WMN6
L402	9965 000 42430	CHIP INDUCTOR 10UH 1.85R
L412	9965 000 42430	CHIP INDUCTOR 10UH 1.85R
LED401	9965 000 42438	LED LAMP 2X5X7MM
LED402	9965 000 42438	LED LAMP 2X5X7MM
LED403	9965 000 42438	LED LAMP 2X5X7MM
LED404	9965 000 42438	LED LAMP 2X5X7MM
LED405	9965 000 42438	LED LAMP 2X5X7MM
LED406	9965 000 42438	LED LAMP 2X5X7MM
LED407	9965 000 42438	LED LAMP 2X5X7MM
LED408	9965 000 42438	LED LAMP 2X5X7MM
Q2	9965 000 38609	TRANSISTORS 2W 8050C
Q401	9940 000 03937	TRANSISTORS PMBT3906
Q402	9965 000 38609	TRANSISTORS 2W 8050C
Q403	9965 000 38609	TRANSISTORS 2W 8050C
Q407	9940 000 03937	TRANSISTORS PMBT3906
REM401	9940 000 00325	OPTIC SENSER (OPTO..)
X401	9965 000 42442	CRYSTAL 10MHZ
X402	9965 000 42441	X'TAL 32.768KHZ -20PPM
	9965 000 42439	LCD DISPLAY FB0668TTN-P

Note: Only these parts mentioned in the list are normal service parts.

ELECTRICAL PARTS LIST - KEY BOARD

LED421	9940 000 01482	LED LAMP 3MM (RED)
LED501	9965 000 42443	LED LAMP 2X5X7MM(S.BLUE)
LED502	9965 000 42443	LED LAMP 2X5X7MM(S.BLUE)
LED503	9965 000 42443	LED LAMP 2X5X7MM(S.BLUE)
LED504	9965 000 42443	LED LAMP 2X5X7MM(S.BLUE)
LED505	9965 000 42443	LED LAMP 2X5X7MM(S.BLUE)
LED506	9965 000 42443	LED LAMP 2X5X7MM(S.BLUE)
LED507	9965 000 42443	LED LAMP 2X5X7MM(S.BLUE)
LED508	9965 000 42443	LED LAMP 2X5X7MM(S.BLUE)
LED509	9965 000 42443	LED LAMP 2X5X7MM(S.BLUE)
LED510	9965 000 42443	LED LAMP 2X5X7MM(S.BLUE)
LED511	9965 000 42443	LED LAMP 2X5X7MM(S.BLUE)
LED512	9965 000 42443	LED LAMP 2X5X7MM(S.BLUE)
SW501	9965 000 42444	TACT SWITCH 6X6MM 4.3MM
SW502	9965 000 42444	TACT SWITCH 6X6MM 4.3MM
SW503	9965 000 42444	TACT SWITCH 6X6MM 4.3MM
SW504	9965 000 42444	TACT SWITCH 6X6MM 4.3MM
SW505	9965 000 42444	TACT SWITCH 6X6MM 4.3MM
SW506	9965 000 42444	TACT SWITCH 6X6MM 4.3MM
SW507	9965 000 42445	TACT SWITCH 6X6MM 7MM
SW508	9965 000 42445	TACT SWITCH 6X6MM 7MM
SW509	9965 000 42445	TACT SWITCH 6X6MM 7MM
SW510	9965 000 42445	TACT SWITCH 6X6MM 7MM
SW511	9965 000 42445	TACT SWITCH 6X6MM 7MM
SW512	9965 000 42445	TACT SWITCH 6X6MM 7MM
SW513	9965 000 42445	TACT SWITCH 6X6MM 7MM
SW514	9965 000 42445	TACT SWITCH 6X6MM 7MM
SW515	9965 000 42445	TACT SWITCH 6X6MM 7MM
SW516	9965 000 42445	TACT SWITCH 6X6MM 7MM
SW517	9965 000 42445	TACT SWITCH 6X6MM 7MM
SW518	9965 000 42445	TACT SWITCH 6X6MM 7MM

Note: Only these parts mentioned in the list are normal service parts.